

VIWA 90
VIWA 115
VIWA 125
VIWA 150

**WALL MOUNTED CONDENSING BOILERS
INSTALLATION AND USER MANUAL**

Viwa 90
Viwa 115

Viwa 125
Viwa 150



CONDITIONS

1. DEAR WARMHAUS CUSTOMER

- 1.1. GENERAL WARNING
- 1.2. GENERAL WARRANTY CONDITIONS
- 1.3. GAS LEAKS

2. INSTALLATION PERSONNEL SECTION

- 2.1. SAFE HANDLING
- 2.2. CONTENTS OF PACKAGE
 - 2.2.1. Sizes and Connections
- 2.3. MOUNTING RULES FOR BOILER
 - 2.3.1. General Rules for Places for Mounting The Boiler
 - 2.3.2. Places Where Hermetic Boilers Cannot Be Mounted
 - 2.3.3. Wall Mounting of Boiler and Selection of Mounting Location
 - 2.3.4. Quick Reference Guide for Air Supply, Ventilation and Chimney Terminal Positioning; BS 6644: 2011, IGE / UP / 10 (ed4) 2014 & BS 5440-1: 2008, BS 5440-2: 2009
- 2.4. NATURAL GAS CONNECTION (DEVICE CATEGORY I_{2H})
 - 2.4.1. Flammable Gas Quality
- 2.5. HEATER AND HOT DOMESTIC WATER INSTALLATIONS
- 2.6. FILLING THE SIPHON FOR CONDENSATION LINE
- 2.7. CONNECTION OF WASTE GAS CHIMNEY PIPE SET AND ACCESSORIES
 - 2.7.1. Environmental Distances of Chimney Outlet Connections
 - 2.7.2. Connection of (Ø100/150 mm) Horizontal Concentric Chimney Set and Mounting Horizontal Concentric Chimney Set to The Boiler
 - 2.7.3. Mounting with Vertical Concentric Chimney Sets
 - 2.7.4. Mounting with Concentric Chimney Sets in The Attic

- 2.8. MOUNTING TO PARTIALLY-PROTECTED OUTER SPACES
- 2.9. ELECTRIC CONNECTIONS
- 2.10. OPTIONAL CONTROLS: ROOM THERMOSTAT, EXTERIOR TEMPERATURE SENSOR AND OTHER
 - 2.11. MOUNTING RULES FOR HYDRAULIC INSTALLATION
 - 2.11.1. Structure of Heating Water
 - 2.11.2. Filling / Emptying Heating System
 - 2.11.3. Discharge of Condensing Water
 - 2.11.4. Circulation Pump (Optional)
 - 2.11.5. Controls For The First Operation of The Boiler
 - 2.12. REQUIRED INSTALLATION ELEMENTS FOR BOILER AND HEATING SYSTEM OPERATION
 - 2.12.1. Parts of Boiler

3. FOR USERS

- 3.1. GENERAL WARNING FOR USER
 - 3.1.1. Use of Boiler
 - 3.2. SELECTION OF SWITCHING ON / OFF / STAND-BY AND SUMMER / WINTER MODES
 - 3.2.1. Positions of Switching On / Off / Summer and Winter
 - 3.2.2. Resetting the Boiler (Re-operate)
 - 3.2.3. Operating in Winter Position
 - 3.2.4. Operating in Summer Position (if a boiler is connected)
 - 3.2.5. Use with Room Thermostat (Optional)
 - 3.2.6. Use of Exterior Temperature Sensor (Optional)
 - 3.2.7. Customization of Boiler Features
 - 3.3. RESTORING FAULTS AND FAILURES
 - 3.3.1. Failure Codes Table
 - 3.4. SUGGESTIONS FOR USING BOILER ECONOMICALLY
 - 3.5. POINTS TO CONSIDER BY USERS FOR WARRANTY CONDITIONS

1. DEAR WARMHAUS CUSTOMER

We congratulate and thank you for choosing Warmhaus wall mounter boiler which shall provide you heating and domestic hot water comfort for years. State-of-art Warmhaus boilers, being manufactured in compliance with standards of the European Union are also exported to many countries. You can utilize our Authorized Technical Service network with professional competence certification for any ordinary maintenance needs of this product produced meticulously with hard work. Our authorized services assure sustaining performance of the device as they shall always provide original spare part services. Please read this manual thoroughly to use your boiler economically, comfortably and efficiently, and store to refer when needed.

It is recommended for efficient use to have assembly done by an authorized dealer approved by the local gas authority and which has the competence and experience for assembly.

1.1. GENERAL WARNINGS

This manual is an integral part of the product, and must be delivered to the new user in case of handover of the appliance. The manual shall be preserved properly and kept in the way to be referred as it contains significant information about use as well as installation of the appliance.



Heating and Domestic Hot Water installations shall be projected and implemented a competent and approved engineering company meeting the criteria prescribed by laws, by observing the current legislation in force.



Installation and maintenance shall be carried out by the competent personnel having sufficient knowledge in the installation industry and professional competence certification in accordance with the legislation in force and in line with the directions of the manufacturer. Hazards which may cause injury of persons, other living beings (animals, plants) and damage to goods may be caused by wrong installation, for which the manufacturer cannot be held responsible.



Natural gas installation project; shall be carried out by one of the dealers authorized by your local gas authority.

Attention! Please note & read the warning and informations on the boiler. Incorrect operation of the boiler can cause significant damage.

For Warmhaus wall-mounted boilers; commissioning, adjustment, maintenance and cleaning must only be carried out by a specialist OR approved service by Warmhaus!

When faults occur in the heating system, the plant must be stopped and damaged parts should only be replaced by an authorized workshop.

The accessories used must correspond to the technical rules and the relevant parts must be approved by the manufacturer in connection with the Warmhaus wall-mounted boiler.

Only APPROVED & ORIGINAL spare parts should be used.

Bolts sealed with paint strictly forbidden to open!



The boiler must not be used by children younger 8 years or invalid persons without supervision.

These seals provide evidence that the replacement of bolts required for safe operation. If the seals are damaged, the guarantee of the device will come to an end!

1.2. TERMS AND CONDITIONS OF WARRANTY



The manufacturer may not be held responsible for any faults caused by noncompliance to the legislation and standards in force and information provided in this manual (and information and instructions provided by the manufacturer in any case), within or out of the scope of the contract, and this also constitute reason for termination of warranty of the appliance.



Only Warmhaus Authorized Service is authorized to carry out electrical connection of the boiler and to energize the boiler.

In case of any material, design or installation faults occurred within the warranty period, maintenance and operation shall be carried out without any charge of labor or spare parts.

(Also see: 3.5 MATTERS TO PAY ATTENTION FOR GUARANTEE CONDITIONS)



This appliance should only be used for its designed intended purposes (to be used in closed-circuit heater installation and production of open circuit domestic hot water production).

. All kinds of other uses are not suitable as well as may create a potential danger.



Manufacturer shall not be responsible for damages occurring due to interventions, false installation and initial starting performed by unauthorized persons and warranty scope shall be void. As the Combi is an appliance having heating system, domestic hot water, natural gas/LPG and electrical connections, do not make and have any interventions made without the authorized service



appliance maintenance operations should be performed by the authorized and competent technical personnel, and Warmhouse Authorized Technical Service Centers constitute assurance for quality. WARMHAUS is not responsible for damages arising from repairs, part replacements and maintenance performed by third persons and companies and combi remains out of the warranty scope under such conditions.



This appliance has been manufactured to be installed in the country specified on its technical registration label. Installing the appliance in any other country than those specified on the plate may cause damage or injury to persons, animals and goods.

WARMHAUS declares that Viwa 90, Viwa 115, Viwa 125 & Viwa 150 boilers comply with the essential requirements of the following directives:

- Gas Appliances Regulation (EU) 2016/426
- Boiler Efficiency Directive 92/42/EEC
- Electromagnetic Compatibility Directive 2014/30/UE
- Low Voltage Directive 2014/35/UE
- Ecodesign Directive 2009/125/EC
- Regulation (EU) N. 813/2013 - 811/2013

Manufacturer: Warmhaus Isıtma ve Soğutma Sistemleri Tic. A.Ş. Bursa Organize Sanayi Bölgesi Park Cad. No:10 16140 Nilüfer-Bursa / Turkey

WARMHAUS A.Ş. reserves the right to make all kinds of technical and commercial modifications without notice, and disclaims any liabilities arising out of printing and spelling mistakes.

WARMHAUS

90 kW



1015 18

115 kW



1015 18

WARMHAUS

125 kW



1015 18

150 kW



1015 18

IMPORTANT INFORMATION

It is a statutory requirement that all gas appliances are installed by competent persons, in accordance with the gas safety (installation and use) regulations (current edition). The manufacturer's instructions must not be taken as overriding any statutory requirements, and failure to comply with these regulations may lead to prosecution. No modifications to the appliance should be made unless they are fully approved by the manufacturer. Gas leaks: do not operate any electrical switch, or use a naked flame. Turn off the gas supply and ventilate the area by opening doors and windows contact the gas emergency service

1.3. GAS LEAKS

NATURAL GAS EMERGENCY LINE

HOW TO ACT IN CASE OF DETECTING NATURAL GAS ODOR



Do not use lighter- matches



Do not turn on, off or unplug the lamps or other electrical appliances.



Ventilate the environment by opening doors and windows.

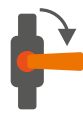

Close valves of appliances operating with natural gas and your gas meter



Do not use/let anyone use the doorbell.



Do not use phones in case of a natural gas leakage. It may create sparks.



Immediately evacuate the place with gas odor.



Call the Natural Gas Emergency Line from your neighbor or another suitable place.



Do not intervene the installation Wait for Gas Authorities Team to arrive.



Never close culverts ensuring discharge of the gas from the environment in case of a natural gas leakage.

IN EMERGENCY CASES



NATURAL GAS EMERGENCY



FIRE DEPARTMENT



AMBULANCE



POLICE

INFORMATION: You can visit web sites of local gas authorities and **NATURAL GAS EMERGENCY** sections.

Advice: Please take note local emergency phone numbers.

1.4 BOILER GAS CATEGORIES & REGIONS

Designation: Used gas types & Countries

Manufacturer		Type Model / Technical Data		Conformity Markings						
Boiler Gas Categories & Regions		Wall mounted type Warmhaus combis and boilers		granted						
Gas categories for Warmhaus boilers are implemented on the CE certificate given below by SZU Test / BRNO;- appliance categories according to direct destinations are determined in accordance with EN 15502-1. According to-EN ISO 3166-1 destination countries;- millibar gas supply pressures, can be used for several gas groups if it is under normal pressure. They are specified with numerical values and "mbar" unit.										
Document for conformity approved by SZU test	Appliance Categories	Gas Type	Gas Inlet Supply Pressures	Used Gas	Lawa 24 Lawa Plus 24 Lawa 28 Lawa Plus 28	Priwa 24 Priwa Plus 24 Priwa 28 Priwa Plus 28 Priwa 33 Priwa Plus 33	Enerwa 24 Enerwa 2530 Enerwa Plus 24 Enerwa Plus 2530 Enerwa 28 Enerwa 3035 Enerwa Plus 28 Enerwa Plus 3035 Enerwa 33 Enerwa 3540 Enerwa Plus 33 Enerwa Plus 3540	Viwa 50 Viwa 65 Viwa 90 Viwa 115 Viwa 125 Viwa 150	Countries of Destination **	
YES	I 2H	Natural Gas	20 mbar	G20	Not Approved	Approved	Approved	Approved	AT, BG, CH, CZ, DK, EE, ES, FI, GB, GR, IE, IT, LT, LV, NO, PT, RO, SE, SI, SK	
YES	I 2H	Natural Gas	25 mbar	G20	Not Approved	Approved	Approved	Approved	HU	
YES	I 2E	Natural Gas	20 mbar	G20	Not Approved	Approved	Approved	Approved	DE, LU, PL, RO	
YES	I 2E+	Natural Gas	20 mbar	G20	Not Approved	Approved	Approved	Not Approved	BE, FR	
YES	I 2E(S)	Natural Gas	20 mbar	G20	Not Approved	Not Approved	Not Approved	Approved	BE	
YES	I 2E+	Natural Gas	25 mbar	G25	Not Approved	Approved	Approved	Not Approved	BE, FR	
YES	I 2L	Natural Gas	25 mbar	G25	Not Approved	Approved	Approved	Not Approved	NL	
YES	I 2ELL	Natural Gas	20 mbar	G20	Not Approved	Approved	Approved	Not Approved	DE	
YES	I 2ELL	Natural Gas	20 mbar	G25	Not Approved	Approved	Approved	Not Approved	DE	
YES	II 2H3P	Natural Gas	20 mbar	G20	Not Approved	Approved	Approved	Not Approved	CH, CZ, ES, FR, GB, GR, IE, RO, SI, SK	
YES	II 2H3P	Propane LPG	37 mbar	G31	Not Approved	Approved	Approved	Not Approved	CH, CZ, ES, FR, GB, GR, HR, IE, IT, LT, PT, RO, SI, SK	
YES	II 2L3P	Natural Gas	25 mbar	G25	Not Approved	Approved	Approved	Not Approved	NL	
YES	II 2L3P	Propane LPG	37 mbar	G31	Not Approved	Approved	Approved	Not Approved	NL	
YES	I 3P	Propane LPG	37 mbar	G31	Not Approved	Approved	Approved	Not Approved	BE, CH, CZ, ES, FR, GB, GR, HR, IE, IT, LT, NL, PL, PT, RO, SI, SK, TR	
EN ISO 3166-1: 2006, Codes for the representation of names of countries and their subdivisions - Part 1: Country codes (ISO 3166-1: 2006)										
Prepared by: İsmail B. Taşdemir / R&D Mng.					Approval; revision was made with E-30-00300-18 GAR certificate and CE-1015CT0615 product number. And correction 02 Viwa 50 and 150 kW addition equivalent.			This document and the information contained herein belong to Warmhaus Isıtma ve Soğutma Sistemleri San. Tic. A.Ş. It shall not be transferred to any person not authorized by Warmhaus Isıtma ve Soğutma Sistemleri San. Tic. A.Ş. or copied or used howsoever by any third persons without prior written approval.		
Date of Publication: 18/4/2017										
Rev. No: 2										
Drw. No: WH.17.107										

Table 1.1

Table 1.2

2. INSTALLATION PERSONNEL SECTION

2.1. SAFE HANDLING

This boiler may require 2 or more operatives to move it into its installation site, remove it from its packaging and during movement into its installation location. Manoeuvring the boiler may include the use of a sack truck and involve lifting pushing and pulling.

Caution should be exercised during these operations. Operatives should be knowledgeable in handling techniques when performing these tasks and the following precautions should be considered:

- Grip the boiler at the base
- Be physically capable
- Use personal protective equipment as appropriate e.g. gloves, safety footwear.

During all manoeuvres and handling actions, every attempt should be made to ensure the following unless unavoidable and/or the weight is light.

- Keep back straight
- Avoid twisting at the waist
- Always grip with the palm of the hand
- Keep load as close to the body as possible
- Always use assistance

WARNING

Caution should be exercised when performing any work on this appliance.

- Protective gloves and safety glasses are recommended.
- Avoid direct contact with sharp edges.
- Avoid contact with any hot surfaces

NOTICE

Please be aware that due to the wet testing of the appliance, there may be some residual water in the hydraulic circuit.

- Protect any surfaces, carpets or floorings.
- Use a suitable container to catch any water that escape when removing the protective caps from the connections.



INSTALLATION

The boiler must be installed in a fixed location, by qualified engineers in compliance with all instructions contained in this manual. Furthermore, the installation must be in accordance with current standards and regulations.

2.2. CONTENTS OF PACKAGE

There are the following materials in the boiler box. In the Viwa 90-150 boiler group, waste gas chimney sets are not supplied with the boiler and must be ordered separately.

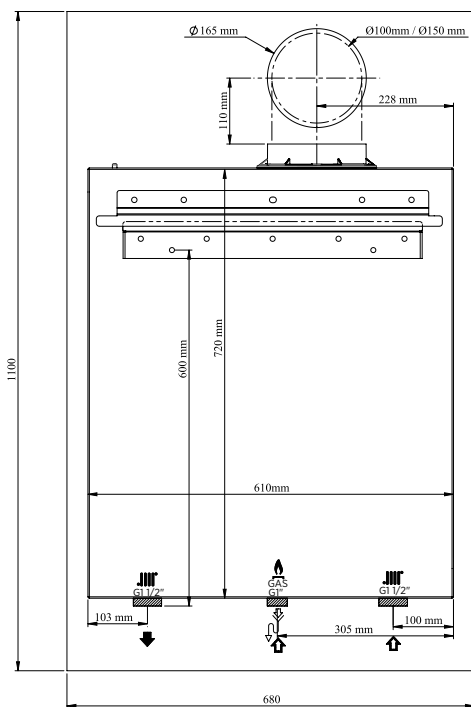

Figure 2.2 Mounting Template of Viwa 90 & Viwa 115 (Back view)

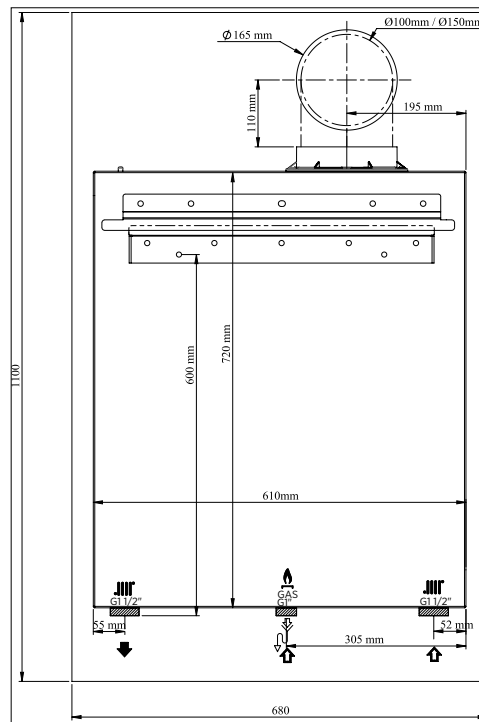

Figure 2.1 Mounting Template of Viwa 125 & Viwa 150 (Back view)

I. Mounting Template (Figure 2.1 and 2.2)

II. User Manual (Figure 2.3)

III. Connection Accessories (Figure 2.4)

- 1 Throttle Screw (mounted on the chimney outlet)
- 2 Hanger Screws
- 2 Dowels

IV. Rod-fastening plate (Figure 2.5)

V. Condensing Siphon (Figure 2.6)



Do not leave the packaging material (plastic bag, nylon, etc.) in a place where children can reach it, in order not to create a health hazard.



Figure 2.3 User manual



Figure 2.4 Connection Accessories

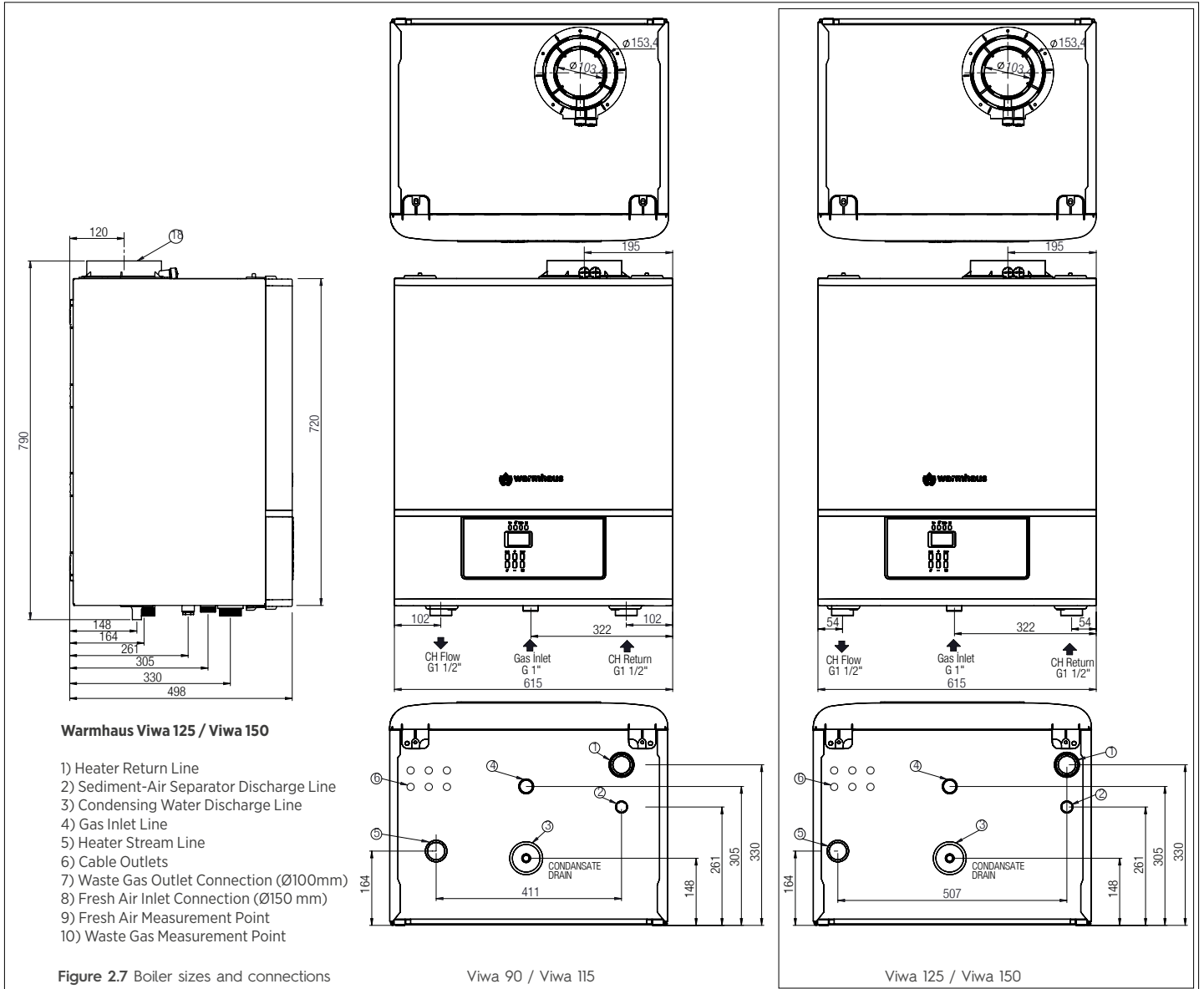

Figure 2.5 Rod-fastening plate



Figure 2.6 Siphon part for discharging condensing water

2.2.1. Sizes and Connections



2.3. MOUNTING RULES FOR BOILER

2.3.1. General Rules for Places for Mounting The Boiler

There is no ventilation limitation for places where the hermetic (C type) boiler is mounted (the devices can be mounted regardless of the volume and ventilation form of the room). In addition, it can be mounted in partially protected areas such as balconies and terraces provided that it is in the protective cabin and necessary precautions are taken against freezing in the installation water. However, the installation requirements of the local gas company in the area to be mounted must also be taken into consideration, so be careful about the mounting locations for over a certain capacity!

The boiler should be mounted firmly on the building wall. A flexible connection element must be used between the boiler and the gas line. Flexure lengths to be used on A, B and C type devices shall not exceed the permissible limits from local gas companies. The chimney outlets of the hermetic boilers must be connected directly to the outdoor with open air circulation. The gas outlet conditions of waste gas installation of these devices should be in accordance with the rules set out in TS 12514 standard (positions of the pipe outlets in relation to various forms, vertical, horizontal minimum distances, cross-sectional areas of the ducts if connected to ducts).

2.3.2. Places Where Hermetic Boiler Cannot Be Mounted

- To the stairwells of buildings
- To the common spaces of the buildings which are open to general use, air wells and day spaces, to the attic, to the under the roof, to emergency exit doors, and similar places such cellar, hall etc.
- To the yards between buildings
- To narrow eaves gaps
- On chimney walls,
- To closed balconies,
- To open balconies except for being in a cabin and permitted by device company and local gas company),
- Underneath the protruding parts of the structure which prevent the outflow of waste gas,
- To places where can be exposed to direct wind pressure
- It is forbidden to mount hermetic boilers (type C) in openings that provide fresh air to other units!

2.3.3. Wall Mounting of Boiler and Selection of Mounting Location

- It must be checked and guaranteed wall-mounting of boiler is sound and safe.

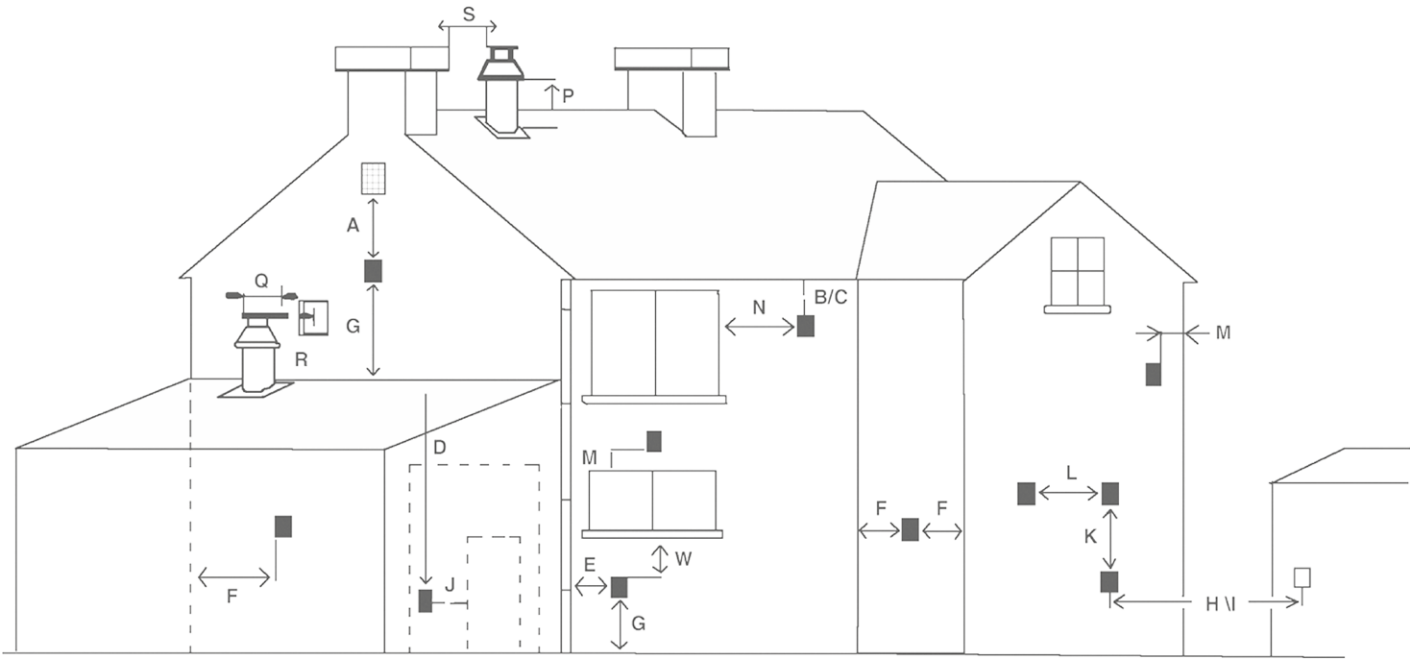

Figure 2.8 Environmental locations of flue

	Chimney Position	Minimum Distance
A	Under a window	300 mm.
B	Under water groove 75 mm.	75 mm.
C	Under fringes 20 mm.	200 mm.
W	Under balcony	200 mm.
E	To vertical water discharge pipes	150 mm.
F	To inside or outside corners	300 mm.
G	To ground, roof or balcony level	300 mm.
H (*)	To another wall corresponding to the wall	600 mm.
S	To another chimney	1200 mm.
J	From the garage wall to another door	1200 mm.
R	From same wall to another chimney (vertically)	1500 mm.
Q	From same wall to another chimney (horizontally)	300 mm.
M	On another window / culvert	300 mm.
N	Horizontally another window / culvert	300 mm.
P	To the roof level	300 mm.
F	To a neighbouring wall	300 mm.
I (*)	On the window on the neighbouring wall	1000 mm.
L	To another chimney	600 mm.

(*) Not recommended for C₅ ve C₆ !

- The hanger plate supplied as standard with the boiler shall be mounted on a full or half-full brick wall in accordance with the connection screws and mounting template in compliance with its technique and shall not be used for any other purpose.
- If different materials are used for mounting, the boiler will be out of warranty.
- If the wall to be mounted on is not a brick wall, the durability of the support system must first be checked.
- The boiler must be mounted on a fire-resistant wall.

- It is recommended to mount the boiler between 1.8 - 2.2 m length of hanger plate from the ground.
- In places where mounting area is limited, the boiler must be mounted minimum 30 cm above the ground, with a space of minimum 5 cm from the sides and 90cm from the front for easy intervention of service technician.
- The boiler is not mounted in places with explosive, flammable material and acid vapor.
- It is not mounted on sides of above cookers, ovens or heating devices.
- Hermetic boilers can be mounted inside the furniture as well, but at least 5 cm spacing should be left on their sides.
- It is advisable to connect the outlet of the boiler to the outlet line by means of a transparent hose to prevent the possibility of water coming from safety valve of boiler after mounting. If this is not possible; do not put electronic devices, tools, parts and equipment that can breakdown, rust, etc. under the boiler.
- Due to the above reasons, it is not recommended to put any furniture under the boiler.

2.3.4. Air Supply, Ventilation and Flue Terminal Positioning Quick Reference Guide for; BS 6644:2011, IGE/UP/10 (ed4) 2014 & BS 5440-1:2008, BS 5440-2:2009, BS6644:2011 Specification for the Installation of gas-fired hot water boilers of rated inputs between 70 kW (net) and 1.8 MW (net) (2nd and 3rd family gases) & IGE/UP/10 2014 Edition 4 Installation of Gas Appliances in Industrial and Commercial Premises

For BS 6644 and IGE UP 10 Installations the ventilation openings might need to be increased if the following air temperatures are exceeded. (@15°C Ambient)

High-Level (100mm Below Ceiling Level)	40°C
Mid-level (1500mm Flow Floor Level)	32°C
Low-Level (100mm Above Floor Level)	25°C

As a guide, reduction of air temperature may be achieved by increasing the inlet and outlet air supply by 0.15 m³/h or 0.2 cm²/kW of net heat input per 0C of temperature reduction required.

Room Sealed Appliances Installed within an Enclosure (Natural ventilation requirements direct to Outside Air)

Grille Location 600m from any obstruction	System Type	Heating &/or HWS Operation < 50% during summer months	Heating &/or HWS Operation > 50% < 75% during summer months	Heating &/or HWS Operation > 75% during summer months
High Level (Free Area/kW)		5 cm ²	6 cm ²	7 cm ²
Low Level (Free Area/kW)		5 cm ²	6 cm ²	7 cm ²

Room Sealed Appliances Installed within an Enclosure (Natural ventilation requirements Via an internal Space)

Grille Location 600m from any obstruction	System Type	Heating &/or HWS Operation < 50% during summer months	Heating &/or HWS Operation > 50% < 75% during summer months	Heating &/or HWS Operation > 75% during summer months
High Level (Free Area/kW)		10 cm ²	11 cm ²	12 cm ²
Low Level (Free Area/kW)		10 cm ²	11 cm ²	12 cm ²

Room Sealed Appliances Installed within a Boiler Room / Heated Space (Natural ventilation requirements direct to Outside Air)

Grille Location 600m from any obstruction	System Type	Heating &/or HWS Operation < 50% during summer months	Heating &/or HWS Operation > 50% < 75% during summer months	Heating &/or HWS Operation > 75% during summer months
High Level (Free Area/kW)		2 cm ²	3 cm ²	4 cm ²
Low Level (Free Area/kW)		2 cm ²	3 cm ²	4 cm ²

Max Operating Pressure < 100mbar, Room Air Change Rate >0.5/hour = No Additional Ventilation. If the air change rate is less than 0.5/hour then the following must be applied.

Appliances without draught diverters with or without draught stabilisers

Grille Location 600m from any obstruction	System Type	Heating &/or HWS Operation < 50% during summer months	Heating &/or HWS Operation > 50% < 75% during summer months	Heating &/or HWS Operation > 75% during summer months
High Level (Free Area/kW)		1.35 +/- 0.18 (m ³ /h/kW)	1.35 +/- 0.18 (m ³ /h/kW)	1.35 +/- 0.18 (m ³ /h/kW)
Low Level (Free Area/kW)		2.6 (m ³ /h/kW)	3.32 (m ³ /h/kW)	4.04 (m ³ /h/kW)

VENTILATION

"Viwa 90 - 150" boilers can be installed in boiler rooms whose size and requirements meet current regulations. The following is provided for your guidance only, and assumes the ventilation air is taken directly from outside. The sizes of the vents may need to be increased in respect of other appliances installed in the same area, and seasonal use. Take care that the position of low level vents would not be subject to adverse weather conditions, ie flooding.

Ventilation requirements for Viwa 90 -150 boilers and cascade systems. BS6644 has a requirement that the temperatures in a room or compartment do not exceed certain levels:

- +25 °C at floor level (0-100 mm)
- +32 °C at mid level (1.5 m above the floor level)
- +40 °C at ceiling level (0-100mm from ceiling)

When installed as a class B appliance (open flued, not roomed sealed). Installed in a room High level (within 15% of the room height from ceiling) - 2 cm²/kW of net heat input Low level (low as possible within 1 metre from floor natural gas) - 4 cm²/kW of net heat input A single Viwa 125 (116 kW net input) boiler would require 232 cm² at high level and 464 cm² at low level. Installed in a compartment or enclosure High level (within 15% of the room height from ceiling) - 5 cm²/kW of net heat input Low level (low as possible within 1 metre from floor natural gas) -10 cm²/kW of net heat input A single Viwa 125 (116 kW net input) boiler would require 580 cm² at high level and 1160 cm² at low level. When installed as a class C appliance (room sealed). Installed in a room High level (within 15% of the room height from ceiling) - 2 cm²/kW of net heat input Low level (low as possible within 1 metre from floor natural gas) - 2 cm²/kW of net heat input A single Viwa 125 (116 kW net input) boiler would require 232 cm² at high level and 232 cm² at low level.

2.4. NATURAL GAS CONNECTION (DEVICE CATEGORY I_{2H})

Our boilers were manufactured to run with methane gas (G20). Gas supply pipes must be equal to or greater than 3/4 "G boiler connections. Before connecting the gas, a careful internal cleaning of the pipe laying of the entire fuel supply installation must be carried out, since possible waste will damage the best performance and efficiency of the boiler. It must be checked that the gas distributed from the main line is in the type stipulated for the boiler (see the label on the boiler).

In addition, the network dynamic pressure (methane) to be used in feeding the boiler and in case of it is inadequate, that may affect the power of the boiler and cause difficulties for the user. Make sure the gas valve connection is made correctly. The flammable gas supply pipe must be designed and dimensioned according to the current MMO and local gas company specifications and instructions in order to ensure that the boiler is capable of delivering sufficient gas to the burner while the boiler is operating at maximum power and the device is efficient. The connection system must comply with legal regulations.

2.4.1. Flammable Gas Quality

The boiler is designed to be used with pure fuel which does not contain foreign substance in; for this reason it is absolutely necessary to add the necessary filter systems in the gas supply line (in order to ensure that the fuel is purified).

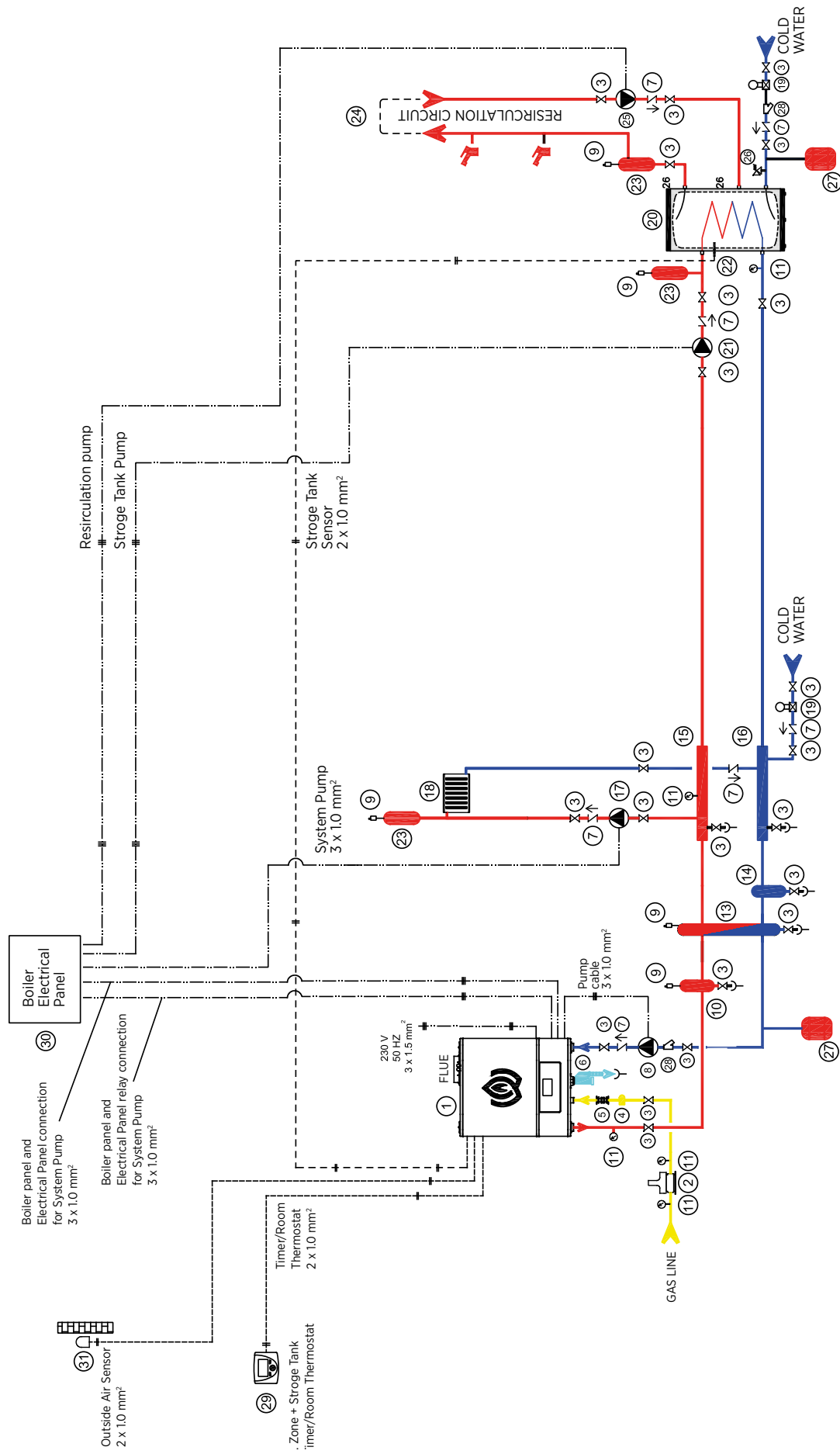

INSTALLATION EQUIPMENT

1. Boiler
2. Gas Safety Solenoid Valve
3. Ball Valve
4. Gas Filter
5. Vibration Isolator
6. Condensate Siphon and Drainage Line
7. Check Valve
8. Boiler (Return) Pump
9. Automatic Air Purge Valve
10. Sediment-Dirt-Air Separator
11. Manometer
12. Hydraulic Separator Sensor
13. Hydraulic Separator
14. Sediment-Dirt Separator
15. Heating System Steam Water Collector
16. Heating System Return Water Collector
17. Heating System Pump
18. Heating System
19. Pressure Reducer
20. Hot Water Tank
21. Hot Water Tank Pump
22. Hot Water Tank Sensor
23. Air Separator
24. Hot Water Tank Recirculation Line
25. Recirculation Pump
26. Safety Valve
27. Expansion Tank
28. Filter
29. Timer/Room Thermostat
30. Boiler Electrical Panel
31. Outside Air Sensor

Figure 2.9 A Radiator Circuit Viwa and A Hot Water Supply connection diagram with Viwa 90 / Viwa 150 boiler

2.5. HEATER AND HOT DOMESTIC WATER INSTALLATIONS

Radiator and floor heating installations should be performed according to TSE and MMO technical specifications according to heat loss calculation. The type and quantity of the radiator and the quantity of piping of the heating installation must also be appropriate for the calculation of heat loss.

- The heating installation must be installed at a pressure enduring at least 6 bar.
- If the city pressure is higher than 6.5 bar, the pressure reducer must be assembled.
- It is recommended that the heating installation be performed as double or mobile line (at least) and avoiding the elbows and joints as many as possible.
- A strainer filter must be definitely installed in return line of heater and if a hot water tank will be used, in inlet line of domestic water (city).
- An additional expansion tank of at least 50 litres should be used depending on the volume of the heating water and the working temperature of the heating circuit (closed circuit).
- If room thermostat and thermostatic radiator valve will be used together; the thermostatic valve should not be installed in radiators in places where the room thermostatic available!
- Radiators longer than 1.5 m must be cross-connected for efficient operation.
- Sheaths should be used in the passages of the heating and hot water from the walls and they should be fixed with wall clamps so as not to incline in the expansion due to heating.
- For Hot Domestic Water supply, an external hot water tank must be connected to the boiler. In case of use with a hot water tank, the three-way valve and hot water tank sensor in the product accessory group must be used.
- The heater must be washed and cleaned of dirt before filling!

2.6. FILLING THE SIPHON FOR CONDENSATION LINE

The condensation siphon must be filled with water after completing wall-hanging of the condensation boiler, electrical connections, heating lines, hot domestic water connections and condensate drainage line (Figure 10).

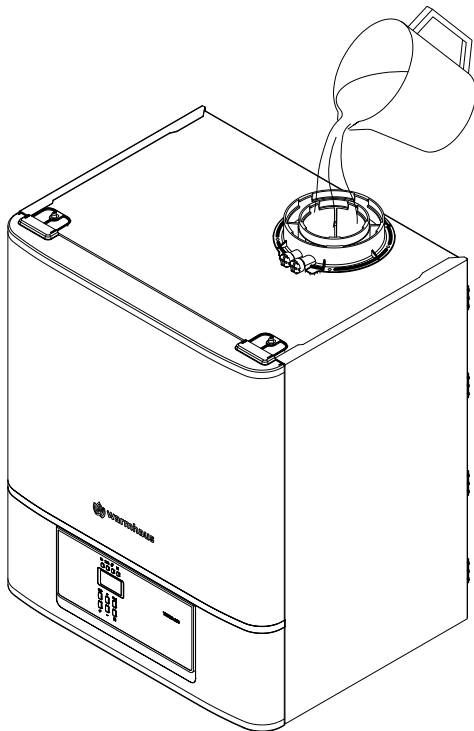

Figure 2.10 Filling the condensation flusher



Condensation line outlet connection must be sealed. However, against the risk of waste gas leak in the first operation, pour about 1 litre of water into the chimney before chimney-mounting of siphon in the boiler. Thus, the water in the siphon will prevent the leakage of waste gas.

The tilt of the condensation water hose and line must always be downward.

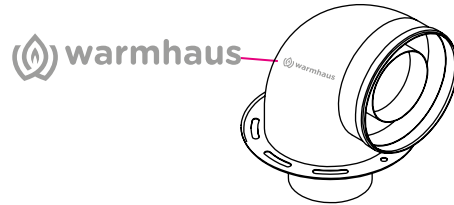

Figure 2.11 There is a Warmhaus log in the chimney elbow.

2.7. CONNECTION OF WASTE GAS CHIMNEY PIPE SET AND ACCESSORIES



Chimney accessory of hermetic boilers sets to be used in the waste gas installation should be original Warmhaus chimney sets and they should be used taking into account sizes and restrictions given in the mounting instructions.



If different waste gas pipes and/or accessories are used other than original Warmhaus waste gas chimney pipes and accessories, the boiler will not be started by the Authorized Service and therefore cannot be guaranteed!

The boiler should only be mounted with plastic material and the original Warmhaus air intake and waste degazing device.

Plastic ducts cannot be installed outdoors, at intervals over 40 cm, without proper protection against UV and weather conditions. Each pipe is identified by a promoting and distinctive Warmhaus sign in the notes.



If more than one Viwa 90-150 boilers are connected in parallel to the same hydraulic installation and operated as cascade, it is necessary to use the product code for each boiler is: Ø100 / 100 Waste Gas Chimney Block with 153.11.660.600040 product code or (Ø100-Ø100) Chimney Block products with 153.11.660.600068 product code must be used for each boiler. In the same installation, the blocks should not be used together and the same block product should be used for each boiler.

If the Viwa 90, Viwa 115, Viwa 125 and Viwa 150 boilers are used as cascade systems and our blocking products are not used in each boiler, boilers will not be started by our authorized service!

IMPORTANT



The following must be checked during starting the boiler:

- Make sure that there is no liquid or combustible materials near the boiler.
- Ensure that the electrical connections are made correctly and that the ground wire is connected to a good grounding system.
- Open the gas valve and check the durability of connections including the burner, burner exchangers and heat exchangers.
- Ensure that the boiler is adjusted for operating for the supplied gas type.
- Check that the chimney pipe in outlet of combustion products is not blocked and is properly mounted.
- Make sure that any (safety) shut-off valve is open.
- Ensure that the system is filled with water and thoroughly ventilated.
- Check that the circulation pump is not jammed.
- Discharge the air that may be in the gas line, discharge the air in the gas pipe by operating the pressure discharge valve at the gas pipe inlet.

→ Air
→ Waste Gas

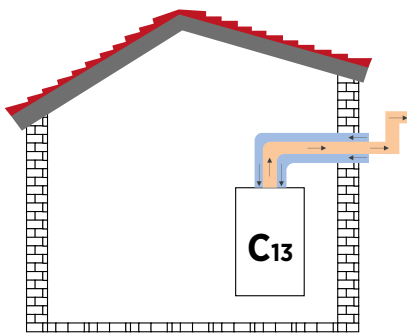

Discharge with Concentric Flue Connection

Caution: In use of C13 type chimney, a 90° cantilever gas directing set must be installed on the cage end.

Figure 2.12 Hermetic (concentric) and Chimney (Split-Flue type)

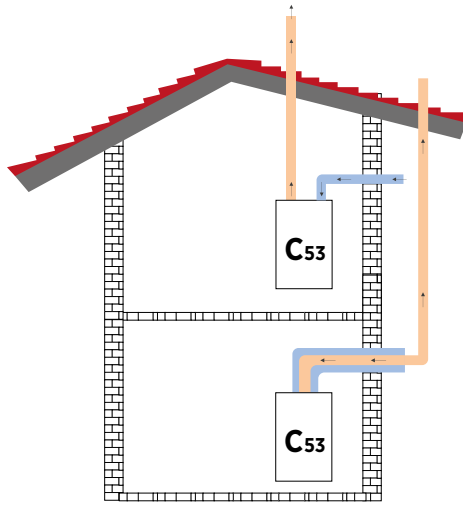

Exhaust Gas Discharge and Fresh Air Intake with Concentric Flue Sets and Split Flue Sets

Caution: Terminals should not be mounted against building walls for supply of combustion air of C5 type sealed boilers with combustion chambers and discharge of combustion products.

Figure 2.13 Hermetic concentric and vertical Split-Flue connection.

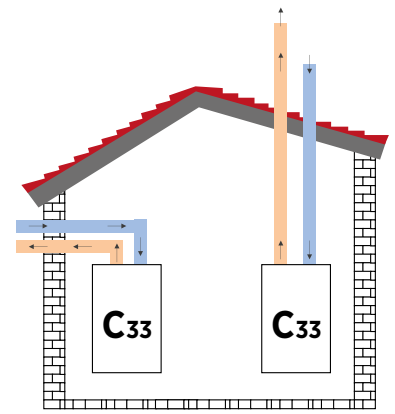

Exhaust Gas Discharge Fresh Air Intake with Split Flue Sets

Caution: In case of using C33 type Split-Flue Set (for horizontal and vertical types), the distance between the exhaust gas outlet and the clean air intake should be minimum 50cm, maximum 100cm.

Figure 2.14 Vertical Type Hermetic Use with Split-Flue Set

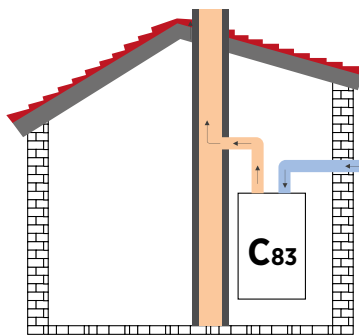

Discharge to Building Chimney with Split-Flue Connection and Fresh Air Intake

- For C8 type sealed boilers with combustion chamber;
- a) overheating combustion products temp.: <math>< 105^{\circ}\text{C}</math>
 - b) CO₂ content; 9.00% (tolerance +0.5%/-0.5%)
 - c) Chimney characteristics to which the boiler can be connected depend on Figure 2.15.
 - d) Condensation water isn't allowed to flow into device.

Figure 2.15 Hermetic vertical Split-Flue connection.

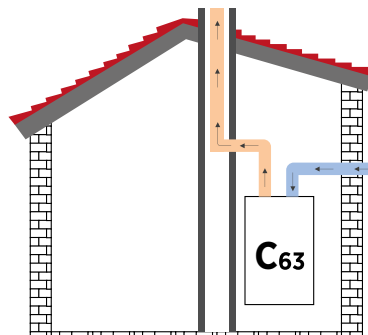

Exhaust Gas Discharge from Building Chimney with Split-Flue Kits and Fresh Air Intake From The Outside

- For C6 type sealed boilers with combustion chamber
- a) for chimney, overheating combustion products temp.: <math>< 105^{\circ}\text{C}</math>
 - b) CO₂ content in nominal operating conditions; 9.00% (tolerance + 0.5% / -0.5%)
 - c) difference of the maximum permissible draught and the maximum permissible pressure between combustion air inlet and chimney gas outlet (including wind pressures): 120 Pa.
 - d) characteristics and applications of the duct system to which the boiler can be connected;
 - 1) Condensation water isn't allowed to flow into device.
 - 2) maximum permissible temperature of the combustion air; 40°C
 - 3) maximum permissible recirculation rate in wind conditions is 10%.
- Caution:** Terminals should not be mounted against building walls for supply of combustion air and discharge of combustion products.

Figure 2.16 Connection of hermetic split-flue and building chimney

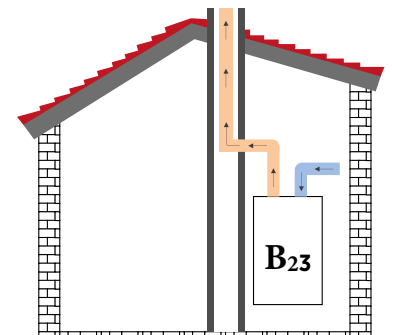

Exhaust Gas Discharge from Building Chimney with Split-Flue Sets and Fresh Air Intake From The Inside

Figure 2.17 Chimney use with split-flue set

2.7.1. Environmental Distances of Chimney Outlet Connections

See Figure 16 for positioning the outlet pipe of chimney set. The chimney must be mounted in accordance with national and local regulations.

Any part of the outlet pipe should not be blocked and should not interfere with other connections. If the outlet pipe is passing 1000 mm near a plastic or painted conduit or 500 mm near the painted eaves, an aluminium guard of at least 1000 mm in length should be placed under the conduit or eaves. The outlet pipe should be at least 2 m above the

surface that people can reach. In some weather conditions, the outlet pipe may emit water vapor; so it should not be mounted in places where this vapor may cause irritation.

It should be ensured that combustion products (waste gas) do not enter the roof ventilation openings. The boiler chimney system can be installed inside the room without the need to intervene on the outside wall. To do this, especially in thick walls, a bed must be used in the wall for lining the inner surface of the duct, through which the outlet pipe passes through the wall.

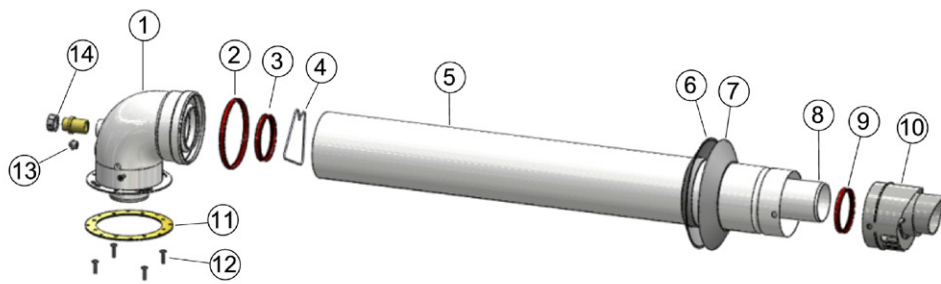

1. 90° elbow
2. Sealing gasket
3. Sealing gasket
4. Centring wire
5. Exterior chimney pipe
6. Inner wall blind flange
7. Outer wall blind flange
8. Interior chimney pipe
9. 60 Sealing gasket
10. Protection cage
11. Flange gasket
12. Flange connecting screws
13. Control measurement stopper
14. Fresh air control cover

Figure 2.18 Ø 80/125 mm Concentric Chimney Set

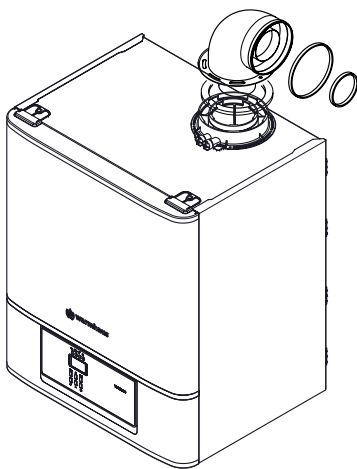

Figure 2.19 Installation of chimney set parts

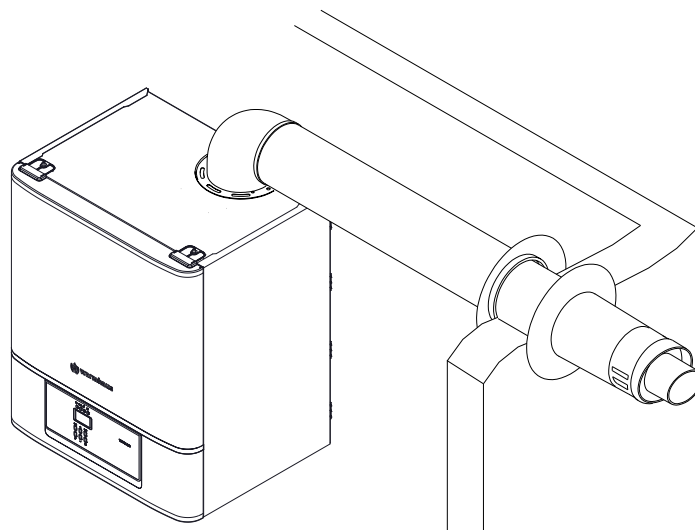

Figure 2.20 Combi concentric chimney wall outlet for hermetic use.

· Concentric extension pipes and plug-in type seal for elbows. To connect the possible extension connections of the waste gas chimneys to other elements of chimneys: connect the male (straight) side of concentric pipe or concentric elbow to the female side (sealed side) of the previous part, in this case make sure you have fitted the required washer, so the connection will be tight and integrity of parts of the set will be ensured.



All horizontally fitted ducts (air/flue) should be fitted at a slight 2° or 3° upwards incline to allow condensate water drain to the boiler.

· The parts of standard horizontal flue kit are available in "Concentric (Optional) Chimney Accessories (Ø100/150 mm) for VIWA 90, 115, 125 and 150".

The horizontal flue connections should be assembled as to have an upwards inclination of 2° or 3° as to allow the return of condensate to the device.

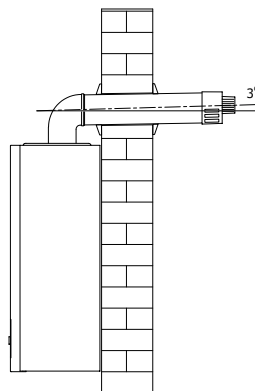

Figure 2.21 Condensed boiler chimney tilt



Please note that in the case where shortening of the discharge chimney and/or extension is required, the inner chimney must always be 5 mm ahead of the outer pipe.



For safety reasons, the absorption/discharge chimney of the boiler should not be blocked, even if for short-time or temporarily.



During installation of the horizontal pipes, the pipe tilt must be kept upwardly a minimum of 3%, dowelled in every 3m and a retaining clamp must be used.

Ø100/150 mm

$a + b + c + d < 19 \text{ m} = (\text{Viwa } 90)$

$19 \text{ m} = (\text{Viwa } 115)$

$18 \text{ m} = (\text{Viwa } 125)$

$10 \text{ m} = (\text{Viwa } 150)$

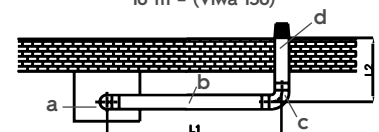

Figure 2.22 II. Two 90° cantilever sample chimney installation

a- Horizontal Chimney Set Elbow (90°)

b-Chimney Extension Pipe

c- Additional 90° Elbow

d-Horizontal Chimney Set Pipe



The total length of the concentric chimney set must not exceed 10m horizontally with a single elbow. In additions, this total length is reduced by 1 m for each 90° elbow use and 0.5m for each 45° elbow use. Up to 3 90° elbow can be used.

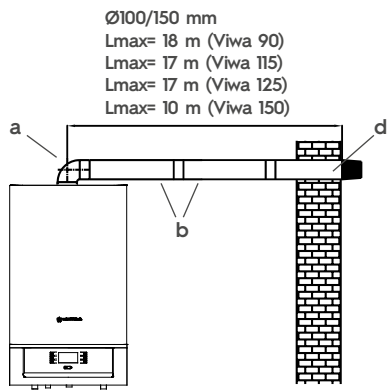

Figure 2.23 Single 90° angled sample chimney installation

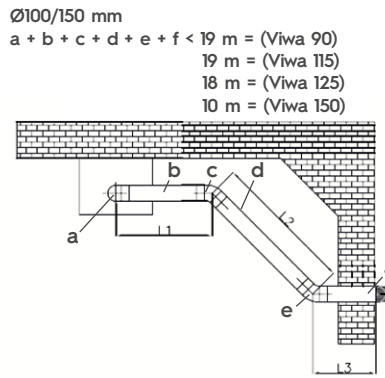

Figure 2.24 III. Single 90° and two 45° angled sample chimney installation

- a- Horizontal Chimney Set Elbow (90°)
- b- Chimney Extension Pipe
- c- Additional 45° Elbow
- d- Standard Chimney Set Pipe
- e- Additional 45° Elbow
- f- Horizontal Chimney Set Pipe

Connection of (Ø100 / 150 mm) Horizontal Concentric Chimney Set and Mounting Horizontal Concentric Chimney Set to The Boiler

Since your boiler is hermetic model, if it is used with concentric chimney sets, it takes the air that it uses from the outside and emits waste gases due to combustion to the outside from the same chimney group. The use and installation of the chimney is very important to avoid emission of waste gases which are extremely harmful, so cautions should be taken into account when connecting chimney.

- Select the chimney necessary for the chimney connection from the mounted place of your boiler and outside. If the horizontal/vertical chimney set is insufficient, select the most appropriate elements from our list of connection accessories, taking into account the warnings mentioned in our operating manual.
- Fix the flange under Elbow part (1) in Figure 17 on holes on the boiler by using the Flange Seal (10) and screwing with the flange connection screws (11).

- Two sealing gaskets (2) from the concentric chimney set are placed in the inner pipe slots at both ends of the 90° elbow.
- To group the chimney outlet terminal, intertwine the outer wall (EPDM) gasket with chimney terminal as seen in Figure 17. After intertwining the chimney outlet terminal from the outer side of wall and previously opened holes insert the Internal Wall Connection Gasket (7) in chimney terminal. Insert the other end of EPDM connection gasket you have already inserted in 90° chimney elbow, into the chimney outlet terminal. Be careful that gaskets are placed properly.

2.7.2. Mounting with Vertical Concentric Chimney Sets

The boiler also has the possibility to connect vertically to the flat and sloped roof by means of the accessories it has according to the situation of the environment you will mount on. In straight connections, (Ø100 / 150 mm) vertical chimney set should not exceed 11m.

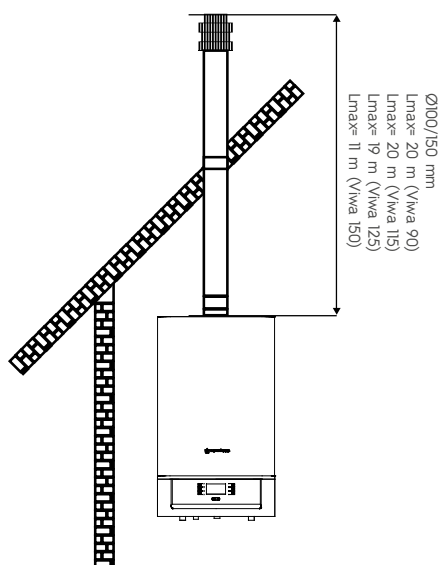

Figure 2.25 Vertical chimney set mounting

In practice

L1	=0.3 m.
L2	=0.5 m. (45° elbow equivalent length)
L3	=4.5 m.
L4	=0.5 m. (45° elbow equivalent length)
L5	=4.7 m.
L6	=1.0 m.
L Total	=11.5 m.

Correct in practice for Viwa 90, Viwa 115, Viwa 125 but **not suitable in practice** for Viwa 150.

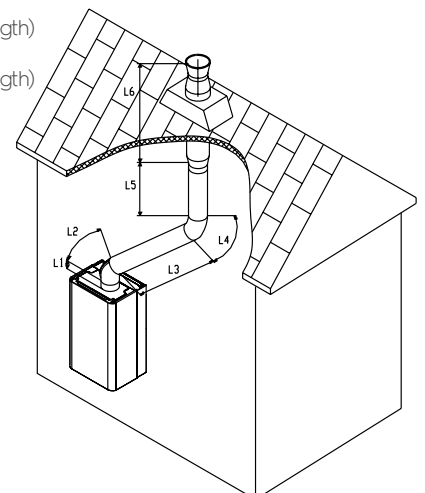
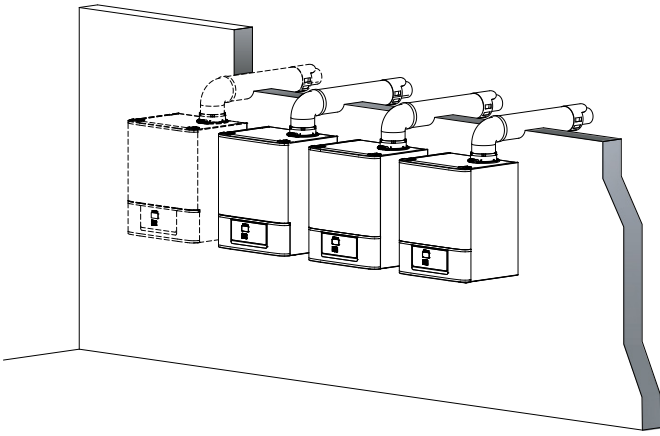

Figure 2.26 Vertical chimney set mounting practice



2.7.3. Mounting with Concentric Chimney Sets in The Attic

In the cascade installations in the attic, waste gas chimney connection of each boiler can be done with concentric (Ø100/150mm) Horizontal or Vertical Chimney Sets. This is in accordance with TS 7363.

Figure 2.27 Cascade Chimney Connection in the Attic with Concentric (Ø100/150mm) Chimney Sets

Concentric (Optional) Chimney Accessories (Ø100/150 mm) for VIWA 90, 115, 125 and 150 Wall-Mounted Condensing Boilers

Baca aksesuarları birbirlerine sıkı geçme ile yöntemi ile monte edilebilir ve bu nedenle bağlantı için ek bir paçaya gerek yoktur.

Product Code	Product Name	Product Explanation	Product Image
153.11.014.000007	Ø 100/150 Horizontal Chimney Set	Maximum Chimney Distances Lmax= 18 m (Viwa 90) Lmax= 17 m (Viwa 115) Lmax= 17 m (Viwa 125) Lmax= 10 m (Viwa 150)	
153.11.660.600042	Ø 100/150 Extension Chimney L=500 mm	Can be used with Horizontal Chimney Set and Vertical Chimney Set.	
153.11.660.600043	Ø 100/150 Extension Chimney L=1000 mm	Can be used with Horizontal Chimney Set and Vertical Chimney Set.	
153.11.660.600040	Ø 100/100 Flue Check Valve	This is an accessory that must be installed at the outlet of each boiler when multiple boilers are used in the cascade system.	
153.11.660.600068	BOB 100.100 Flue Check Valve	If more than one boiler is used in the cascade system, Non-angled flap accessories must be inserted on to each boiler's flue outlet. The boiler connection and the collector connection are Ø100 mm	
153.11.660.600044	Ø 100/150 Elbow (90°)	Can be used with Horizontal Chimney Set and Vertical Chimney Set. Each 90° elbow use requires a reduction of 100cm from the maximum horizontal/ vertical distance.	
153.11.660.600041	Ø 100/150 Vertical Chimney Set	Maximum Chimney Distance Lmax= 20 m (Viwa 90) Lmax= 20 m (Viwa 115) Lmax= 19 m (Viwa 125) Lmax= 11 m (Viwa 150)	

The chimney accessories can be mounted each other by close-fit method, so there is no need for an additional part for the connection.

2.8. MOUNTING TO PARTIALLY-PROTECTED OUTER SPACES

Installation instructions: This boiler can be installed in partially-protected outer spaces. Partially-protected place means that the boiler is located at places where it is not directly exposed to atmospheric factors and precipitation (rain, snow, hail, etc.).

Protection Against Freeze: The boiler is equipped with a system that automatically prevents the freezing by putting the pump and the burner into operation when the water in the boiler falls below 5 °C. The protection against freeze depends on the following conditions:

- If the boiler is correctly connected to gas and electricity sources;
- If the boiler is supplied constantly from gas and electricity sources (if main switchgear is on)
- If the boiler does not come to the fault condition due to lack of ignition;
- In order to ensure the circulation of the installation water, the installation valves and radiator valves under the boiler must be in the open position. Under these conditions the boiler is protected against freeze up to an ambient temperature of -5 °C.

The lowest temperature -5°C. If the temperature of the boiler is mounted in an environment that may be below -5 °C and if the gas inlet is cut off or the ignition fails, the Anti-Freeze System will not be put into practice and freezing/icing will occur in the device. The following instructions must be followed to prevent freeze risk:

- Protection against freeze by placing in the heating circuit an anti-freeze in a percentage of the required minimum temperature for the heater by a well-known antifreeze producer (special for heating appliances) in which the heater is intended to be stored, and by carefully following the instructions.

The materials from which the boilers are made are resistant to ethylene glycol and propylene-based icing inhibitor liquids. Observe suppliers' warnings about their life and possible disposal methods.

Protecting the boiler against freeze/icing is only guaranteed on these conditions:

Damage caused by failure to comply with the foregoing and interruption of electrical energy shall be excluded in the effectiveness of the guarantee.

If the boiler is mounted in places where the temperature falls below 0 °C (both for domestic use and for heating purposes), both the heating installation and the domestic water pipes must be insulated.

2.9. ELECTRIC CONNECTIONS

The electric safety of the boiler takes place only if it is fully connected to an effective grounding system, as stipulated by the current safety regulations. If there is no grounding, the grounding shall not be made on the socket through neutral line! The use of gas and water connection pipes for grounding is dangerous and unacceptable.

WARMHAUS A.S. cannot be held responsible for any damage or loss that may occur to a person or property due to the absence of grounding connection of the boiler and the failure of grounding by an authorized electrician to comply with the applicable regulations and standards.

Also check that the electrical installation meets the maximum power that can be pulled specified in the technical specifications label on the boiler. Boilers should be connected with "X" type special power supply cables without socket. The Warmhaus boilers have a protection level of IPX5D. Power supply cable must be connected to a 230 V + 10%; - 15% 50Hz network with L-N polarity and grounding connection; on the same network, a high voltage category IIIrd class multi-pole contact cutter should be installed. When it is necessary to change the cable, be sure to contact our Authorized Warmhaus Service.



The power supply cable must follow the specified route. If the fuses on the adjustment card are to be replaced, use a 2A or 3.15A quick-type fuse. The use of adapters, multiple sockets and extension cables is not permitted for the device to be supplied from the general electric network.

2.10. OPTIONAL CONTROLS: ROOM THERMOSTAT, EXTERIOR TEMPERATURE SENSOR AND OTHER

Control devices such as Room Thermostat, Exterior Temperature Sensor, etc. must always be connected to Warmhaus boilers by an authorized service personnel. If the connections are made by unauthorized persons, the boiler will be out of warranty.



Control devices such as Room Thermostat, Exterior Temperature Sensor, etc. are provided to Warmhaus boilers as optional accessories and must be Warmhaus certified.

See use instructions for placing the Exterior Temperature Sensor.

This sensor, which can be connected directly to the electrical installation of the boiler, automatically reduces the maximum stream water temperature at the installation when the exterior temperature increases to run the temperature sent to the heating installation in compliance with the exterior temperature changes. The Exterior Temperature Sensor is actuated when connected independently of the typology of the room thermostat used and works in conjunction with room thermostats. The relationship between the installation inlet temperature and the exterior temperature is determined according to curves in the diagram from the position of the button on the boiler panel (or on the control panel if connected to the boiler) (Figure 3.2).

The electrical connection of the Exterior Temperature Sensor should be made on pins no. 3-4 in the Low Voltage range where terminal pins 1-14 are located in the boiler electronic board (Figure 2.28).



Figure 2.29 RC21.13 Room Unit with Heating Area Programming and Hot Water Tank Programming for Temperature Control and Hot Domestic Water

TECHNICAL INFORMATION

Sizes and Weight: 128x99x36mm (compatible with box 503) 130g
Power Supply: Bipolar and nonpolar cable
Power consumption: Max 18V (normal use), Max 23mA (max 250mW)
Charging capacity: Max 24h (after at least 3 hours charge)
Room sensor sensitivity: +/- 0.5°C at 25°C
Time accuracy: +/- 15 min/year (maximum deviation)
Operating temperature: 0 to 50°C
Protection classes: EN 60730: II IP EN 60529: IP20 (if wall-hanged)

Installation Instruction: Installation of the device should only be carried out by a Warmhaus Service Partner. The dual cable required for installation is supplied by the dealer/consumer.

Electrical Diagram



Designation : **Viwa 90 & 150 - commercial boilers**

Object	Manufacturer	Type-model / Technical data	Mark (s) of conformity
Burner control	BERTELLI	HDIMS50	granted

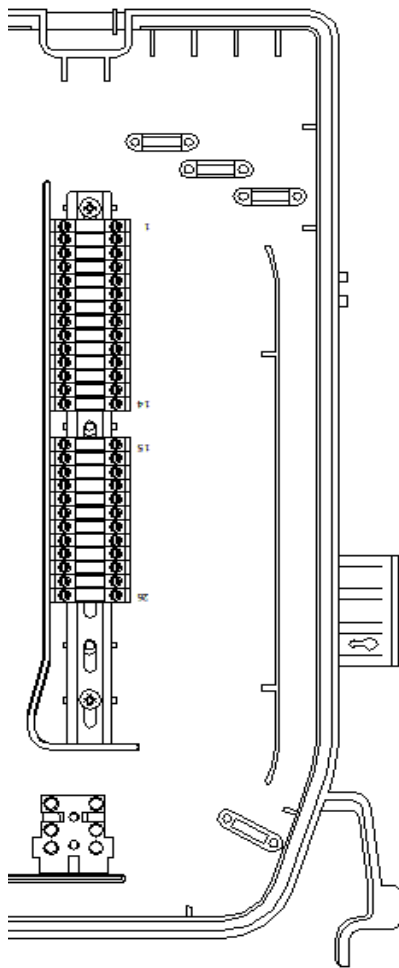

LOW VOLTAGE

1	Brown	DHW / TANK SENSOR
2	Blue	DHW / TANK SENSOR
3	Green	OUTSIDE SENSOR - MASTER
4	Green	PLANT SENSOR - SLAVE
5	White	OPENTHERM
6	White	OPENTHERM
7	Orange	AUX (Parameter 52) SENSOR
8	Orange	AUX (Parameter 52) SENSOR
9	Blue	TA 1 ZONE THERMOSTAD
10	Blue	TA 1 ZONE THERMOSTAD
11	Brown	TA 2 ZONE THERMOSTAD
12	Brown	TA 2 ZONE THERMOSTAD
13	White	PUMP PWM GROUND
14	Red	PUMP PWM

HIGH VOLTAGE 230 V - 50Hz

15	Red	Z2. PUMP FREE CONT.
16	Red	Z2. PUMP FREE CONT.
17	Blue	Z1. PUMP NEUTRAL
18	Black	TA1. HIGH V. LIVE
19	Brown	Z1. PUMP LIVE
20	Black	AUX LIVE
21	Blue	AUX NEUTRAL
22	Green-Yellow	GROUND ↓
23	Green-Yellow	GROUND ↓
24	Blue	NEUTRAL
25	Brown	N.CLOSE - LIVE
26	Black	N.OPEN - LIVE

DHW 3-WM /PUMP

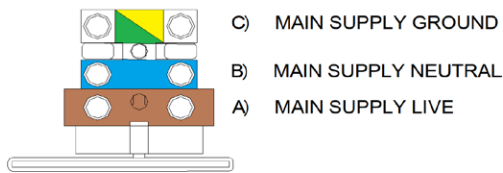

HIGH VOLTAGE SIDE

Plug	n. pin	Description of the pin	Notes
HIGH VOLTAGE	C	MAIN SUPPLY GROUND	Green-Yellow
	B	MAIN SUPPLY NEUTRAL	Blue
	A	MAIN SUPPLY LIVE	Brown

LOW VOLTAGE SIDE

Plug	n. pin	Description of the pin	Notes
LOW VOLTAGE	1	DHW / TANK SENSOR	Brown
	2	DHW / TANK SENSOR	Blue
	3	OUTSIDE SENSOR FOR MASTER	Green
	4	PLANT SENSOR FOR SLAVE (IF ANY)	Green
	5	OPENTHERM	White
	6	OPENTHERM	White
	7	AUX SENSOR (PARAMETER 52)	Orange
	8	AUX SENSOR (PARAMETER 52)	Orange
	9	TA 1 ZONE THERMOSTAD	Blue
	10	TA 1 ZONE THERMOSTAD	Blue
	11	TA 2 ZONE THERMOSTAD	Brown
	12	TA 2 ZONE THERMOSTAD	Brown
	13	PUMP PWM GROUND	White
	14	PUMP PWM	Red

HIGH VOLTAGE SIDE

Plug	n. pin	Description of the pin	Notes
HIGH VOLTAGE 230 VAC 50 Hz	15	Z2 PUMP FREE CONTACTS	Red
	16	Z2 PUMP FREE CONTACTS	Red
	17	Z1 PUMP NEUTRAL	Blue
	18	TA1 HIGH VOLTAGE LIVE	Black
	19	Z1 PUMP LIVE	Brown
	20	AUX LIVE	Black
	21	AUX NEUTRAL	Blue
	22	GROUND	Green-Yellow
	23	GROUND	Green-Yellow
	24	DHW 3 WM - NEUTRAL	Blue
	25	DHW 3 WM - NORMALLY CLOSE	Brown
26	DHW 3 WM - NORMALLY OPEN	Black	

Author	Ismail B. Taşdemir / R&D Mng.	Appr.:	As this is the property of Warmhaus Isıtma ve Soğutma Sistemleri San. Tic. A.Ş. It must not be passed on to any person not authorized by Warmhaus Isıtma ve Soğutma Sistemleri San. Tic. A.Ş or be copied or otherwise utilized by anybody without expressed written permission.
Release date	16.7.2018		
Rev. No:	2		
Drw. No:	WH.17.714		

Figure 2.28 Electrical diagram for room thermostat, outdoor air temperature sensor and other installation elements to be connected to the boiler.



The room thermostat should be installed at a distance of 1.25 to 1.5 m from the floor.



It should be at least 30 cm away from the open door and window edges to air flow.

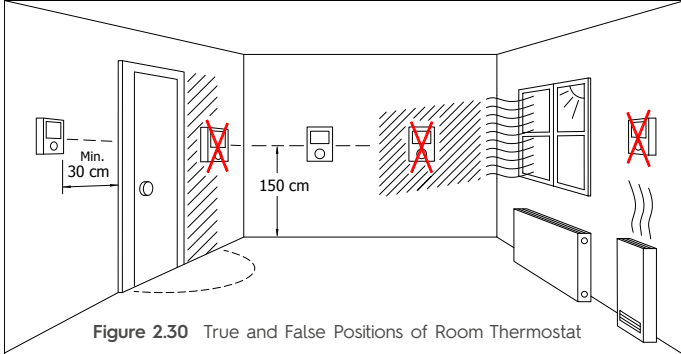

Figure 2.30 True and False Positions of Room Thermostat

2.11. MOUNTING RULES FOR HYDRAULIC INSTALLATION

2.11.1. Structure of Heating Water



Caution: Before making the connection to the boiler, make sure that any residues in the main heat exchanger (pipes, heating appliances, etc.) are removed using solvents or similar



Preventive water treatment procedure for cast aluminium heat exchange

The following descriptions describe the quality of water required for aluminium heat exchangers. In order to obtain the required heat transfer, the installation water must be of good quality. Parameters such as PH, hardness, conductivity, oxygen, flux residues, oil residues and corrosion products due to installation can have negative effects on the heat exchanger.

Before filling (old and new) the installation, it should be thoroughly rinsed in accordance with EN 14336 with clean running water from the faucet.

For water treatment Warmhaus only permits the products listed below. For the protection and long-term use of the heat exchanger, Warmhaus always specifies the following criteria for the quality of the installation water and the filling water:

- PH should be kept between 6.5 and 8.5.
- The maximum permissible chlorine content for the aluminium heat exchanger is 250 mg/litre.

1. Boiler
2. Gas Safety Solenoid Valve
3. Ball Valve
4. Gas Filter
5. Vibration Isolator
6. Condensate Siphon and Drainage Line
7. Check Valve
8. Boiler (Return) Pump
9. Automatic Air Purge Valve
10. Sediment-Dirt-Air Separator
11. Manometer
13. Hydraulic Separator
14. Sediment-Dirt Separator
15. Heating System Steam Water Collector
16. Heating System Return Water Collector
17. Heating System Pump
18. Heating System
19. Pressure Reducer
27. Expansion Tank
28. Filter
29. Timer/Room Thermostat
30. Boiler Electrical Panel
31. Outside Air Sensor

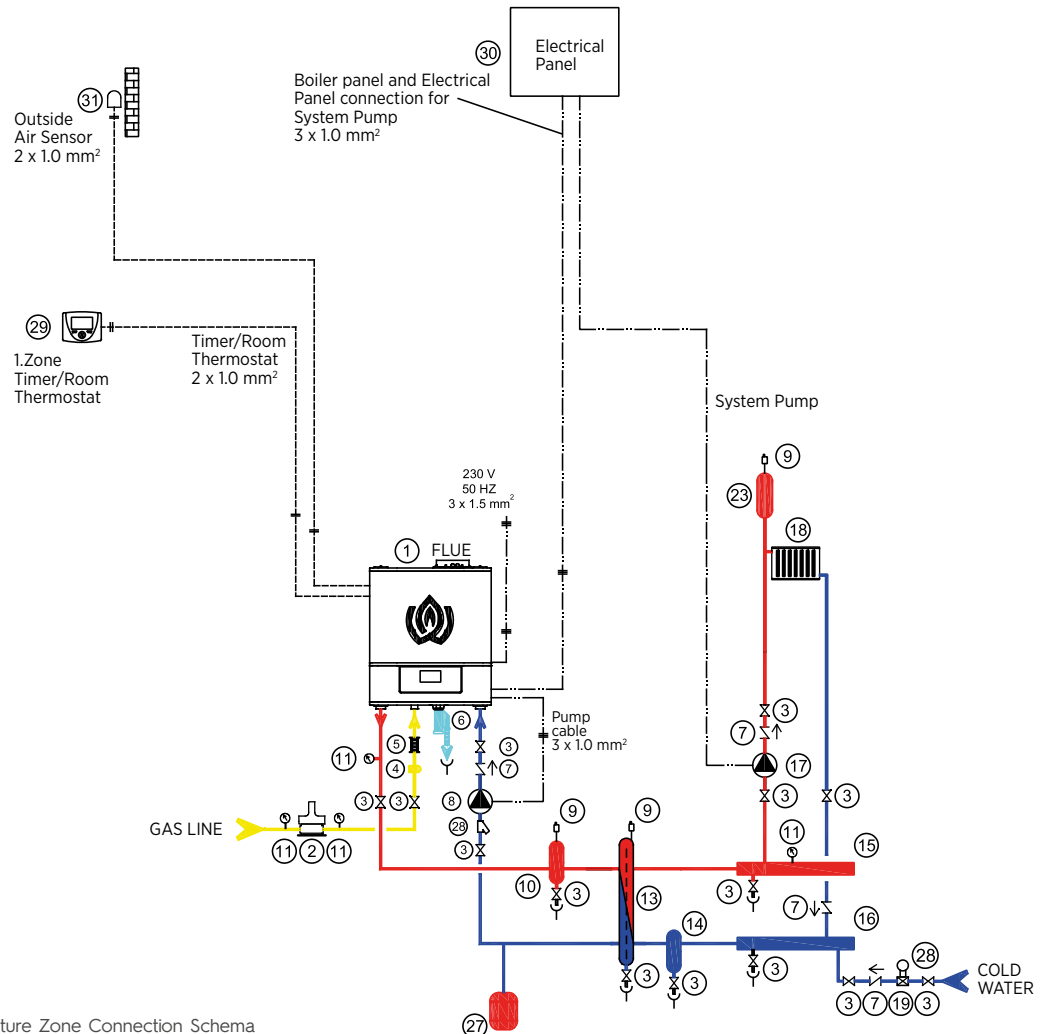

Figure 2.31 Single Boiler and 1 High Temperature Zone Connection Schema

- The maximum permissible sulphate and nitrate content to limit the microbiologically affected corrosion (MIC) risk is 100 mg/litre.
- Strong oxidizing chemicals should be avoided. Some examples of oxidizers include, but are not limited to: chlorine (Cl₂), hydrogen peroxide (H₂O₂), bromine (Br₂), ozone (O₃), chlorine dioxide (ClO₂), sodium hypochlorite (NaClO), potassium hypochlorite lime (Ca(ClO)₂). Strong oxidizers are often added as biocides to the water to reduce microbiological activity of the water.
- Strong complex actuators should be avoided. The most likely to occur are: chlorides (Cl⁻), ammonia and ammonia containing chemicals (NH₃, amines, EDTA, etc.), polyphosphates (such as Calgon). Strong complex actuators are also known as “chelates” (EDTA, NTA), are commonly used to control scaling by typically forming fixed heat-soluble complexes with calcium and magnesium.
- The installation should be designed so that all air can be discharged, ensure that all air is discharged after installation. Preferably, you can also install air separators.
- The total volume VT of water filled, refilled and completely filled throughout the lifetime of boiler at a total hardness of 11°d or 11°dH (-2mmol/litre) shall not exceed the following values: 15 litres/kW x [kW] for Viwa 90-150 series, Taking into consideration that the water in the installation is likely to be completely filled up several times over the lifetime of the heat exchanger, the maximum values in the application must not exceed the following values: 7.5 litre/kW x [kW] for Viwa 90-150 series.

Example:

Viwa 90 boiler 90 kW, the total volume of the installation is 1100 litres. The maximum permissible hardness for Viwa 90 can be obtained from 7.5 litres/kW at 11°d.

This is $7.5 \times 90 \times 11 = 7425$ litres. °d

The maximum permissible hardness at 1100 litres, the total volume, is $7425/1100 = 6.8$ °d.

This means that the water in the installation must be softened to a value of 6.8°d or less.

Example 2:

Viwa 150 boiler 150 kW, the total volume of the installation is 5,000 litres. The maximum permissible hardness for the Viwa 150 can be obtained from 7.5 litres/kW at 11°d.

This is $7.5 \times 150 \times 11 = 12,375$ litres.

The maximum permissible hardness for a total volume of 5,000 litres is $12,375 / 5000 = 2.48$ ° d.

This means that the water in the installation must be softened to a value of 2.48°d or less.

The following table shows the other examples of maximum water hardness in °d.

In all cases, the maximum hardness of the water in the installation must be less than 25°d.

Water treatment

- In the case of water softening by ion exchange, the mixed ion exchange is preferred. Additional pH buffering should then be provided.
- Avoid cation exchange with K⁺ or Na⁺. If cation exchange with K⁺ or Na⁺ is used, pH control is required to limit the pH variation over time.
- In the case of water softening by anion exchange, only methods using sulphur (SO₄²⁻) as negative ion are allowed. Ion exchange methods using Cl⁻ or CO₃²⁻ negative ions are not allowed. If demineralization is used, a chemical additive will be added for pH control.
- Never fill the system with distilled water, as this will seriously corrode the aluminium heat exchanger.
- In order to limit the risk of corrosion, the water conductivity should preferably be less than 100 µS/cm.
- The conductivity of untreated installation water should not exceed 600 µS/cm.

- If the installation water is treated with one of the products described below and according to the manufacturer's instructions, the conductivity must not exceed 1500 µS/cm.
- If the conductivity is higher than the specified values, empty the system and clean and fill with clean tap water according to EN 14336, preferably with recommended cleaning products.
- There are many products in the market claiming to clean and protect the heating systems. Unfortunately, there are a few products that have actually proved this in practice. For this reason, Warmhaus only allows the following quality products for water treatment;

Manufacturer : Fernox (www.fernox.com)

- Cleaner F3 : Removes corrosion, lime and sludge
- Protector F1 : Protects against corrosion, lime and sludge
- Alphi-11 : Prevents freezing and provides protection against corrosion and lime

Manufacturer: Sentinel (www.sentinelprotects.com)

- X 100 : General inhibitor protection
- X 200 : Noise reduct
- X 300 : System cleaner for new installations
- X 400 : System renewing sludge cleaning for old installations
- X 500 : Protective antifreeze and general protection

Manufacturer: Clariant (www.antifrogen.clariant.com)

Antifrogen-L : antifreeze (mono ethylene glycol) (Note: Antifrogen-N is toxic, Antifrogen-L is recommended)

Note that all these products must be used strictly in accordance with the instructions of the water treatment manufacturers.

We also strongly recommend the following:

- Use a register to fill, refill, completely fill water, water quality measurements and water treatment.
- Use only non-diffusing material, especially for underfloor heating.
- Always install air discharge devices at the highest point in the installation.
- In order to avoid as much as possible of filling, refilling and completely filling, place ball valves near the boiler on the installation and in strategic locations (anticipating future expansion of the system).
- Install a water meter to check the amount of filled, refilled, and completely refilled water.
- Install a filter in return.
- In case of any doubt, install a plate heat exchanger to hydraulically separate the boiler from the installation.
- Prevent leaks; If there is a leak, repair it as soon as possible.

We recommend that you add this description of the preventive water treatment to your installation and operating manual.

The above-mentioned water quality requirements apply to aluminium heat exchangers.

The requirements of other parts in the installation are not taken into account.

ABD Conversion::

1 litre	= 0,264 USA gallon
1 °dH	= 0,959 gpg
1 kW (NCV)	= 3,792 MBTU/s (GCV)
1 litre/kW	= 0,0697 USA gallon/BTU/s

All information contained in the above descriptions is based on reasonable research, but does not guarantee any end result.

2.11.2. Filling / Emptying Heating System

After installation of the boiler, a supply connection from the network line must be made with a ball valve with the purpose of filling in heating installation line to fill the closed-circuit heating installation.

Open this valve and ensure that the pressure in Manometer reaches up to 1-1.5 bar and close the Filling Valve by turning it clockwise and redischarge the air of radiators with air discharging valves.

The boiler's safety valve discharge needs to be connected to a discharge hopper. Otherwise, the safety valve is activated and the manufacturer cannot be held responsible for the water drainage to the device's place.

2.11.3. Discharge of Condensing Water

For discharge of the condensation water generated by the device, it must be connected to the waste water network via at least $\varnothing 19\text{mm}$ pipes which are resistant to acidic condensation water. The connection of the device with the waste water network should be made as to prevent the liquid contained in the connection system from freezing. Before operating the device, make sure that the condensation water has been properly drained, then confirm that the siphon is filled with condensation before the first operation (Figure 2.10). In addition, it is necessary to pay attention to the applicable national and local regulations, in order to carry out the instructions for the discharge of waste water.

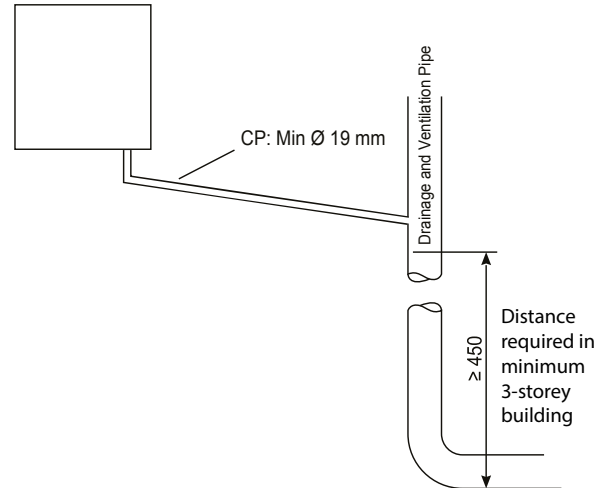

Figure 2.32 Connection of Condensing Water Drainage Pipe to Internal Drainage and Ventilation Pipe

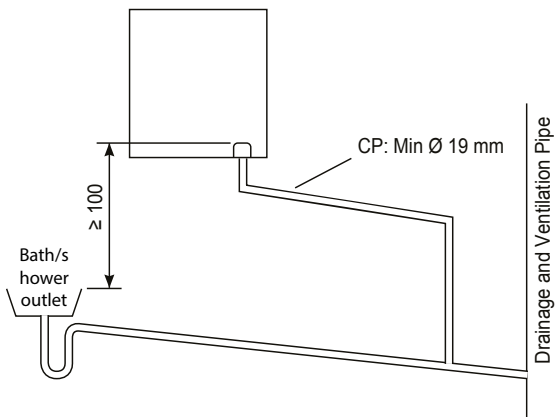

Figure 2.33 Connection of Condensing Water Drainage Pipe to Bottom Level of Interior Bath Outlet Siphon

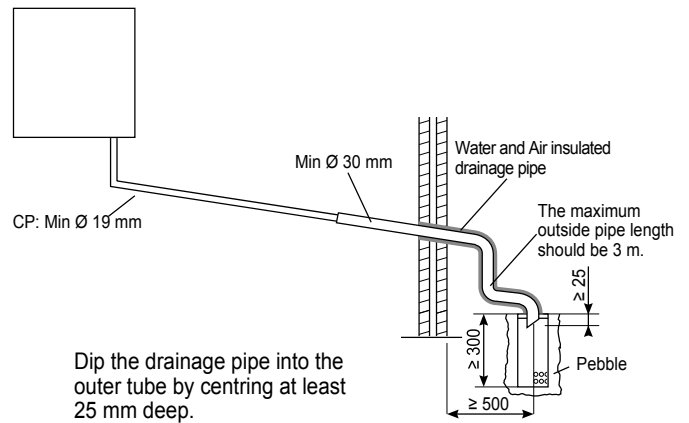

Figure 2.34 Connection of Condensing Water Drainage Pipe on Exterior Environment

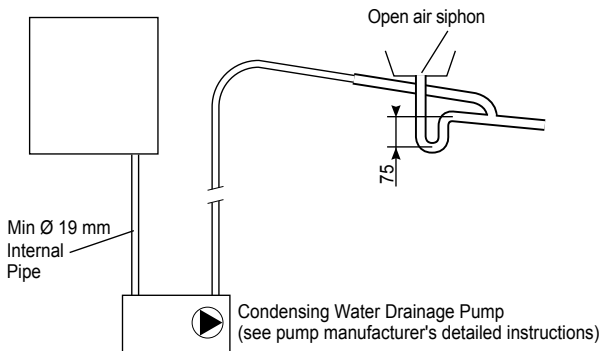

Figure 2.35 Typical Connection Method of a Condensing Water Drainage Pump (see pump manufacturer's detailed instructions)

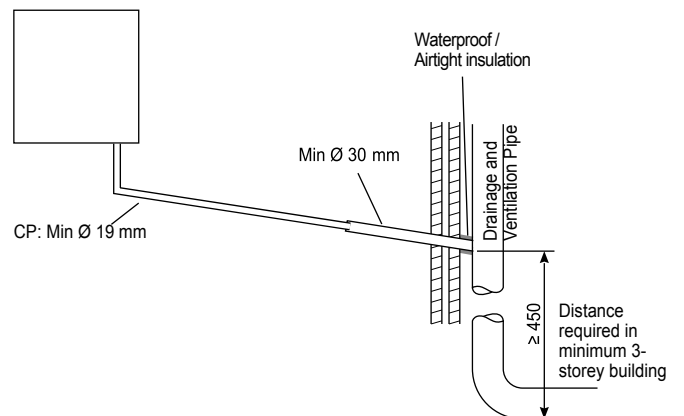

Figure 2.36 Connection of Condensation Drainage to Drainage and Ventilation Pipe

CP (Condensing Pipe): The horizontal pipe connections should be assembled as to have an downwards. Inclination must be minimum 3° as to allow the non-return of condensate to the device.

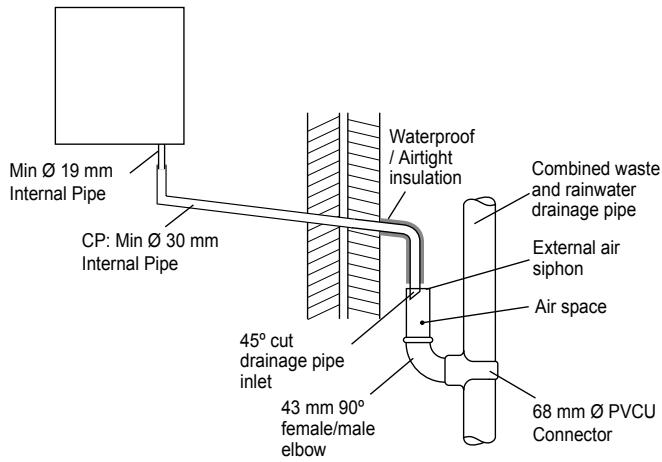

Figure 2.37 Connection of Condensation Drainage to Rainwater Pipe

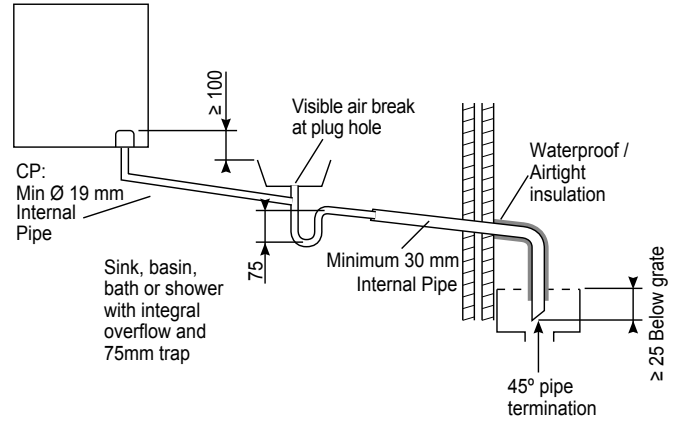

Figure 2.38 Connection of Condensing Drainage Pipe to External Rain Water Drainage from outlet of Sink, Bathtub or Shower Waste Water

2.11.4. Circulation Pump (Optional)

Since Viwa boilers are provided without a pump, it must be used with a pump that will provide the required flow rate for the critical line pressure

loss for the heating system. Warmhaus recommends the frequency converter pump that is provided as OPTIONAL in Figure 2.29 and in compliance with European Energy efficiency directives (ErP) for good performance and energy saving.

WILO-Yonos PARA

High Flow Rate
 PARA 25-130/8 (G 1 1/2)



Boiler Pump Selection Table		
Boiler Model	Explanation	Pump Code
Viwa 90 Viwa 115 Viwa 125	Wilo-YONOS PARA HF 25/7 pump set to be used under Viwa 90 boiler, modulating pump, 2 unions, check valve and gasket set.	152.11.003.000002
Viwa 150	Wilo-YONOS PARA HF 25/10 pump set to be used under Viwa 125 boiler, modulating pump, 2 unions, check valve and gasket set.	152.11.003.000003



Pump Set Image for Viwa 90, 115, 125 and 150

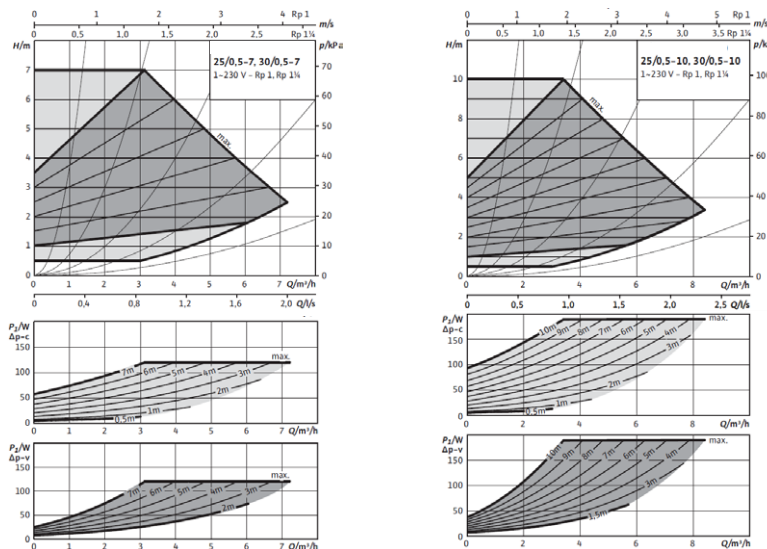

Hydraulic Operating Area $\Delta p-v / \Delta p-C$

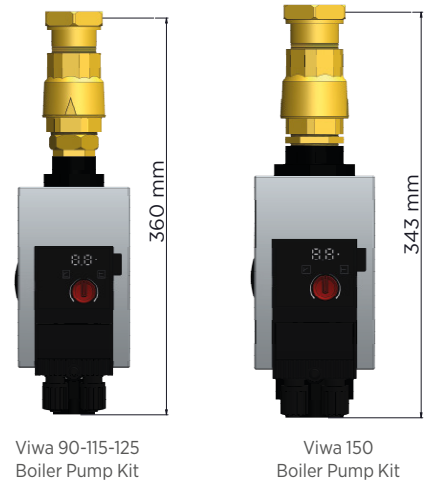

Viwa 90-115-125 Boiler Pump Kit

Viwa 150 Boiler Pump Kit

Figure 2.39 High-pressure and high-flow pump connection set accessories for wall-mounted boilers.

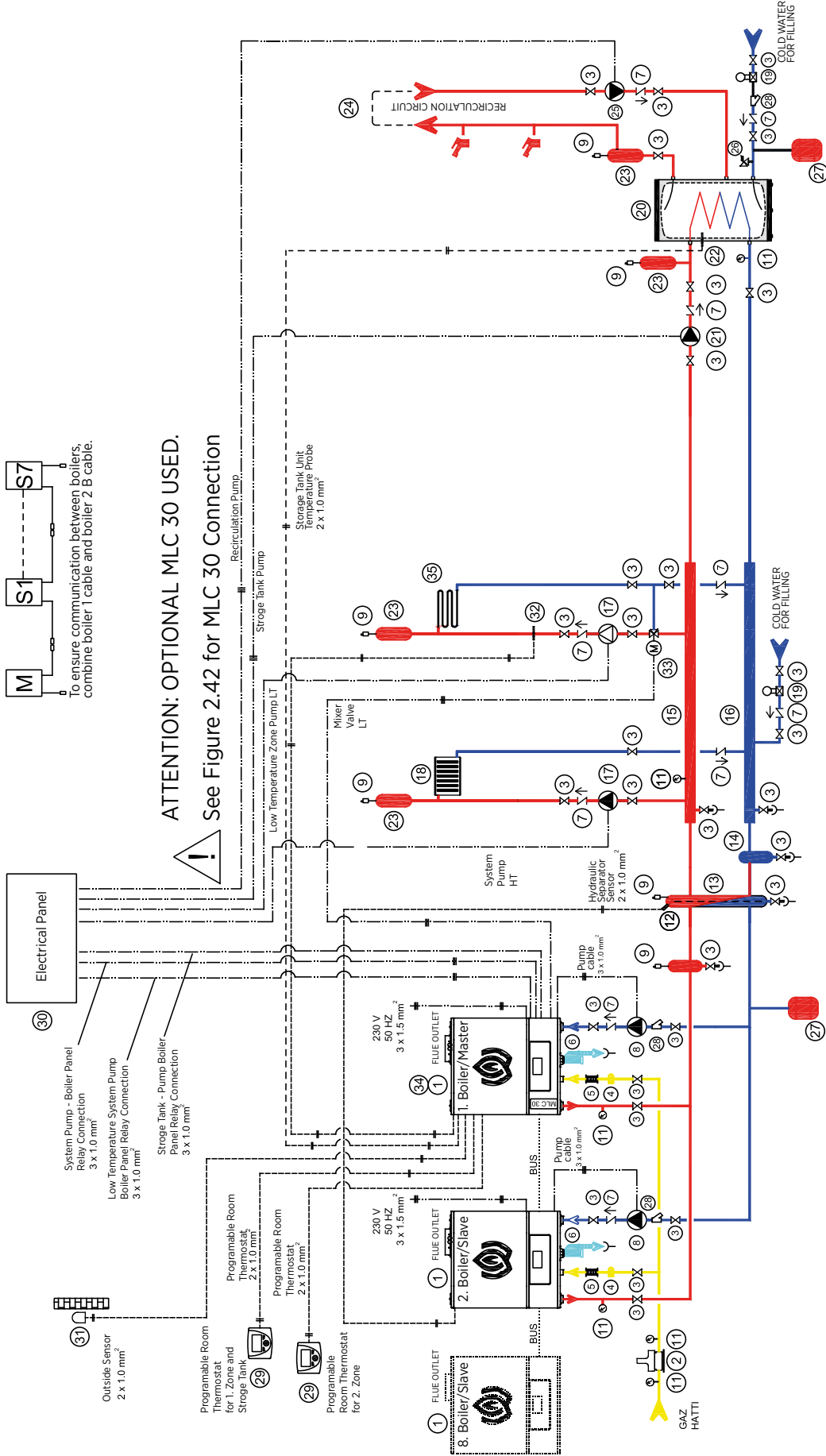

INSTALLATION EQUIPMENTS

- 1. Boiler
- 2. Gas Safety Solenoid Valve
- 3. Ball Valve
- 4. Gas Filter
- 5. Vibration Isolator
- 6. Condensate Siphon and Drainage Line
- 7. Check Valve
- 8. Boiler (Return) Pump
- 9. Automatic-Air Purge Valve
- 10. Sediment-Dirt-Air Separator
- 11. Manometre
- 12. Hydraulic Separator Sensor
- 13. Hydraulic Separator
- 14. Sediment-Dirt Separator
- 15. Heating System Steam Water Collector
- 16. Heating System Return Water Collector
- 17. Heating System Pump
- 18. Heating System
- 19. Pressure Reducer
- 20. Hot Water Tank
- 21. Hot Water Tank Pump
- 22. Hot Water Tank Sensor
- 23. Air Separator
- 24. Hot Water Tank
- 25. Recirculation Line
- 26. Safety Valve
- 27. Expansion Tank
- 28. Filter
- 29. Timer/Room Thermostat
- 30. Boiler Electrical Panel
- 31. Outside Air Sensor
- 32. Low Temperature Zone Sensor
- 33. 3-Way Motorized Valve
- 34. MLC 30 - OPTIONAL KIT
- 35. Low Temperature Zone

Figure 2.40 Viva 90, 115, 125 and 150 Boilers and Cascade System and Multi-Zone System Connection Diagram

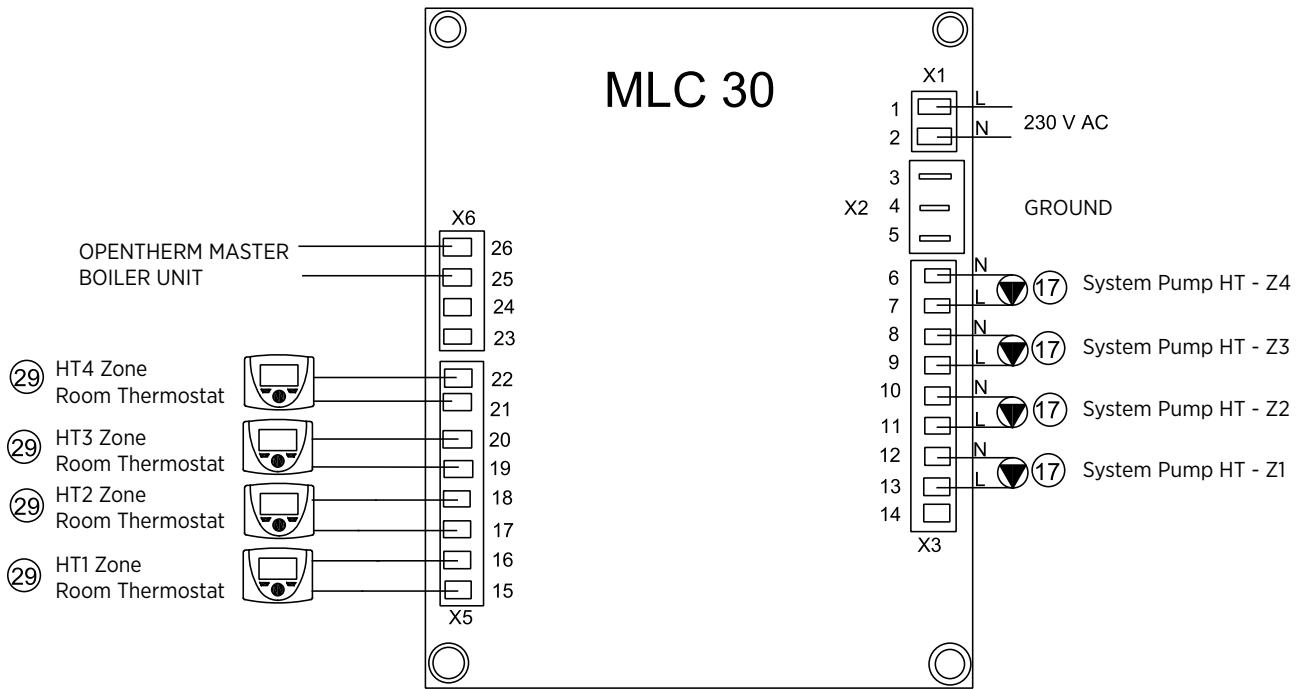

Figure 2.41 Viwa 90, 115, 125 and 150 Boilers and Cascade System and 4 High Temperature (Radiator) System Boilers and MLC30 Electrical Connection Diagram

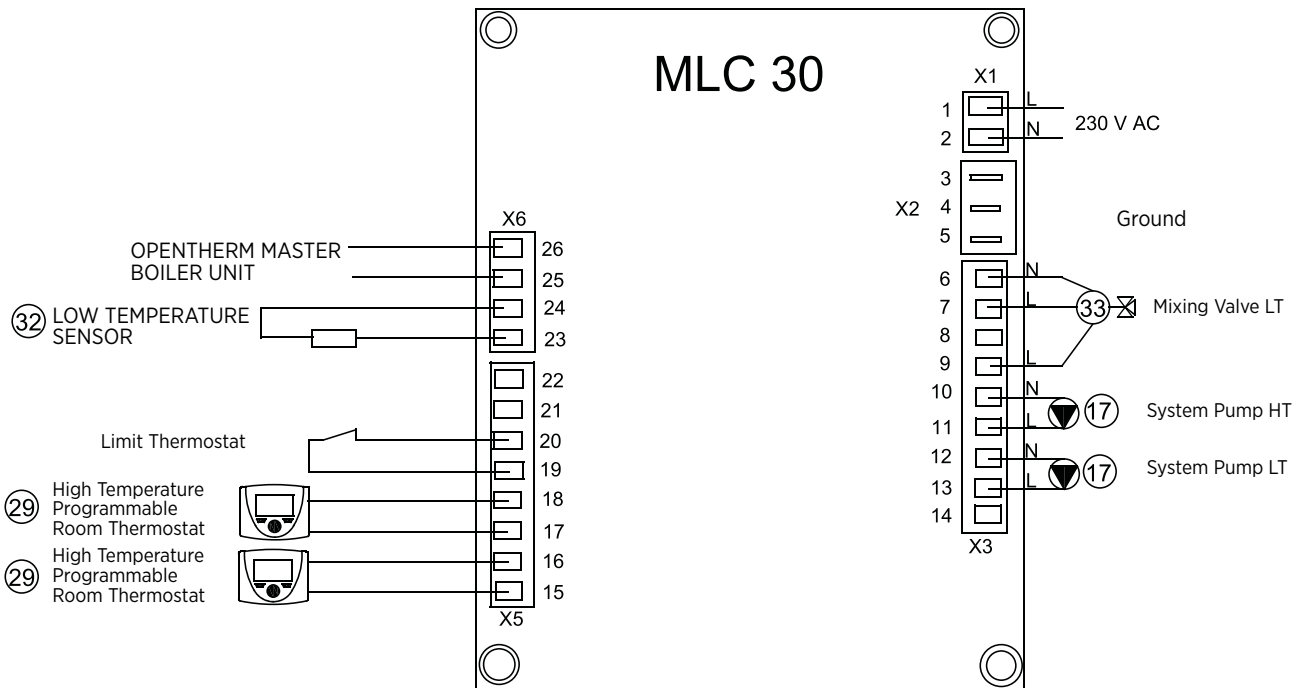



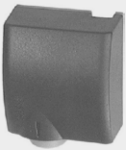











Figure 2.42 Viwa 90, 115, 125 and 150 Boilers and Cascade System and 1 High Temperature (Radiator) and 1 Low Temperature (Local Heating) Zone Boiler and MLC30 Electrical Connection Diagram

Control Accessories for Cascade System

Accessory Code	Accessory Name	Explanation	Compatible Product	Product View
153.11.660.600001	WDHS-01-Exterior Temperature Sensor	Sensor that allows the boiler to regulate according to exterior temperature.	Viwa 50-150	
153.11.660.600045	RC 21.11-Room Thermostat with Timer	Unit that can be used as a thermostat OR timer to provide weekly/daily program to heater and boiler circuit	Viwa 50-150	
153.11.660.600049	QAZ36-Hot Water Tank / Hydraulic Separator Sensor - Immersion Type	The immersion type sensor that will be used to measure the Hot Water Tank or Hydraulic Separator temperature and report to boiler	Viwa 90-150	
153.11.660.600050	QAD36-System Stream Sensor- Surface Type	A clamp-type sensor that provides temperature measurement over the pipe at the outlet of the Hydraulic Separator. It is used to measure the stream water temperature of low temperature zone in double-zone systems.	Viwa 90-150	
153.11.660.600053	MST80 Adjustable Surface Thermostat	A clamp-type adjustable thermostat for heating zone.	Viwa 50-150	
153.11.660.600047	MLC 30-Multi Zone Module	Unit controlling the Low Temperature/Underfloor Heating Zone (mixed valve circuit) of Viwa 90, Viwa 115, Viwa 125 and Viwa 150 boilers.	Viwa 50-150	
152.11.003.000005	RVS-AVS Cascade Panel Set	This set is for the cascade and zone management system which involves RVS 43 boiler control device, AVS 37 display module and RVS-AVS connection cable.	Viwa 50-150	
153.11.660.600051	RVS 43.345 / 101 Boiler Controller	Control unit for Viwa 90 - 150 Boilers that can cascade over OpenTerm for up to 8 boilers (up to 15-cascade) With RVS 43, 1 Radiator Circuit, 1 Underfloor Heating Circuit and 1 Hot Water Tank can be managed.	Viwa 90-150	
153.11.660.600056	OCI 365.03 / 101 Openterm Module	Communication unit for each boiler if RVS unit is used for Viwa 90 - 150 Boilers	Viwa 90-150	

Accessory Code	Accessory Name	Explanation	Compatible Product	Product View
153.11.660.600057	AVS 37.294 / 509 RVS Display Module	1 must be purchased if RVS unit is used for Viwa 90 - 150 Boilers RVS unit control display	Viwa 90-150	
153.11.660.6000	AVS 82.490 / 109 RVS-AVS Connection Cable [40 cm]	1 must be purchased if RVS unit is used for Viwa 90 - 150 Boilers The cable that provides the connection between the RVS unit and the control display or RVS unit and AVS75 unit or AVS75 unit and AVS75 unit (with each other)	Viwa 90-150	
153.11.660.600058	AVS 82.491 / 109 RVS - AVS Connection Cable [100 cm]	1 must be purchased if RVS unit is used for Viwa 90 - 150 Boilers The cable that provides the connection between the RVS unit and the control display or RVS unit and AVS75 unit or AVS75 unit and AVS75 unit (with each other)	Viwa 90-150	
153.11.660.600071	QAC34/101 Exterior Temperature Sensor	1 must be purchased if RVS unit is used for Viwa 90 - 150 Boilers. The sensor that must be connected to the RVS unit.	Viwa 90-150	
153.11.660.600072	QAA55.110/101 Room Unit (Basic)	Small screen room thermostat with Economy and Comfort mode selection and adjusting temperature	Viwa 90-150	
153.11.660.600073	QAA74.611/101 Room Unit (Advanced)	Wide and Illuminated screen room thermostat with Economy and Comfort mode selection and adjusting temperature	Viwa 90-150	
153.11.660.600074	AVVS75.390/101 (Additional Module)	ZONE EXPANSION MODULE (Module for additional zone with 3 relay outputs)	Viwa 90-150	
153.11.660.600077	OZW672.01-Web Server 1 LPB Device	The OZW672.01 web server connected to the RVS 43 Boiler Controller allows remote monitoring and monitoring of the heating center via web and smartphone application.	Viwa 90-150	

2.11.5. Controls for The First Operation of The Boiler

In order for the Boiler not to be excluded from warranty coverage; its first operation must definitely be done by the Warmhaus Authorized Service. The following preliminary preparations must be made before requesting an authorized service appointment:

- For your gas line, a gas approval certificate from the local gas company must have been obtained,
- Electrical connection should have been made with a 2 or 3 Amp fuse at the mounting site of the boiler,
- Make sure there is no power cut at the mounting site of the boiler,
- Make sure that there is no city water cut at the mounting site of the boiler,
- Make sure that the heater is supplied with water and the pressure in the boiler manometer is 1.2 - 1.5 bar.

2.12. REQUIRED INSTALLATION ELEMENTS FOR BOILER AND HEATING SYSTEM OPERATION

To use the condensed boiler as a single unit or as a cascade, the following installation elements must be definitely available in the heating installation;

- A hydraulic separator must be used for ideal heat and pressure distribution of the boiler and installation. However, when the installation pressure is

higher than the maximum boiler pressure, when no oxygenbarrier pipe is used on the installation side and in old installations where steel pipes are used and have started to rust, the boiler/boilers must be separated from the heating installations by using Plated Heat Exchanger in a way remaining no direct connection.

- Air Separator
- Sludge/Sediment Holder
- Expansion Tank (If the system is separated by a plate exchanger, at least one expansion tank must be placed in the return line of the cascade side and the return line of the heating system side)
- It is mandatory to have Filter (Strainers) elements in each boiler return line.

These are essential accessories for your heating system to ensure efficient operation and long life, and to keep your device in warranty. These accessories are not supplied with the boiler.

BOILER PARAMETERS must be set according to the mounting options. Cascade boilers

It should be noted that the installation parameters each boiler constituting the heating system specified on the CASCADE INSTALLATION PROCEDURE (when the boiler is used as cascade) must be changed in the sequential/cascade installations using polypropylene waste gas collectors with Chimney Block.

2.12.1. Boiler Parts

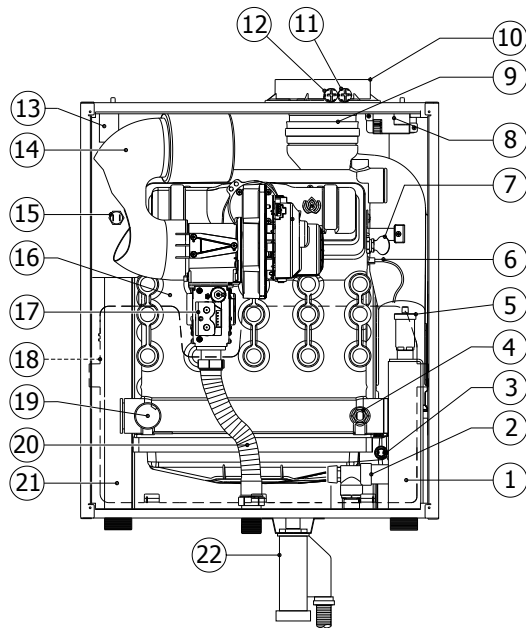
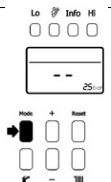
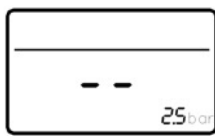
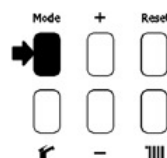

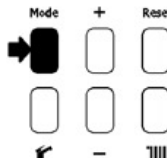
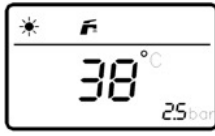

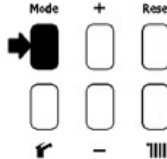



Figure 2.43 Boiler parts

1. Heater Return Line
2. Safety Valve Discharge Line (6 bar)
3. Chimney Over Temperature NTC Sensor
4. CH Return NTC Sensor
5. Automatic Air Discharge Purger (boiler return line)
6. Ignition and Ionization Electrode
7. Flame Surveillance Mirror
8. Ignition Transformer
9. Exhaust Gas Discharge Chimney (Ø100 mm)
10. Fresh Air Intake (Ø150 mm)
11. Air Intake Measuring Point
12. Chimney Gas Measurement Point
13. Automatic Air Discharge Purger (boiler stream line)
14. Air Suction Silencer
15. High Limit Thermostat
16. Main (Burning) Exchanger
17. Gas Valve
18. Main PCB Control Panel
19. Pressure sensor
20. Gaz Intake Pipe
21. Heater Stream Line
22. Condensation Siphon

ON-OFF Mode

Pos No	Operation	Description
0		<p>By Pressing MODE button to select switch mode of the boiler. MODE order is OFF > SUMMER > WINTER > OFF as circle.</p>
1		<p>Make sure that the " - " is displayed on the screen to show device is OFF. If not press again the "MODE" and repeat the step above. On the display " - " symbol shown.</p>
2		<p>to Switch boiler SUMMER MODE - ON press the "MODE" ones again.</p>
3		<p>SUMMER MODE - ON : On the LCD only " SUN "symbol displayed.</p>
4		<p>SUMMER MODE - ON : On the LCD only " SUN " symbol displayed. If DHW request the TAP symbol shown on the screen</p>
5		<p>to Switch boiler WINTER MODE - ON press the "MODE" ones again.</p>
6		<p>WINTER MODE - ON : On the LCD only " SNOW " symbol displayed.</p>
8		<p>to Switch boiler OFF press the "MODE" ones again.</p>
9		<p>Make sure that the " - " is displayed on the screen to show device is OFF. If not press again the "MODE" and repeat the step above. On the display " - " symbol shown.</p>

3. FOR USERS

3.1. GENERAL WARNING FOR USER

3.1.1. Use of Boiler

If there is a gas odour in the environment, first turn off the gas valve of your home and the gas valve of your boiler or, if you are using bulk gas, your LPG tank valve or tube valve. Do not turn on/off the power switches and do not perform any action that can remove the spark. Call your gas company or an Authorized Service. (See 1.3 GAS LEAKS)

Our Authorized Service will give you information about how you will use your boiler after checking and first-operating it.

Before using, check the following:

- The heating system and gas valves under the boiler are open,
- From manometers under the boiler, heating installation pressure is between 1 and 1.5 bar and the system air is discharged and the hot water tank valves are open if there is a hot water tank connection in the system,
- There is gas in your gas line (you can control by turning on one of your gas cookers),,
- Boiler electric fuse is open,
- There are no materials or products next to the boiler that can easily flame,

Burning grades of building materials are shown in the table below. Boilers at least 25 cm away from the operating grade B, C1 and C2 should be. For spark-ignition C3 materials that burn quickly after burning, this distance must be at least twice the distance, ie at least 50 cm.

Building Materials Flammability Classification	Material Name
A - Fireproof	Granite, sand, stone, brick, ceramic
B - Hardly burning	Fiberglass material, heraklit, basalt,...
C1 - Difficult to ignite	Beech and oak boards, plywood, verzalt ...
C2 - Moderately flammable	Pine mart, cardboard, plastic soles
C3 - Easy burning	PVC, polyethylene, polystyrene, polyurethane, pitch ft,...

- The outlet of exhaust gas chimney set is not closed,
- If a room thermostat or control device is connected, it is in the ON position,

- If you are not going to use the boiler during the winter season when freezing/icing conditions exist and if you want to shut it down, perform the following



- Definitely empty the heating water without antifreeze,
- Close the boiler's electrical fuse, gas valve, heater and domestic water valves!

If you are going to turn off the boiler for a short time, perform the following::

- Do not turn off the boiler's electric fuse, gas valve, heater and valves!
- Leave the boiler in Stand-by (stated OFF on the display) so that its Protection Against Freeze function is enabled,

Turn the boiler off during maintenance and repair work around the waste gas discharge chimneys. Make the Warmhaus Authorized Service check the boiler before operating it after operations are finished.

Follow the basic rules below::

- Do not clean the outer casing of the boiler while the boiler isoperating and do not use easily-flammable materials, only use adamp or dry cloth.
- Do not hold the boiler when your hands or feet are wet;also, do not hold without shoes.
- Do not pull electrical cables.
- If the cables are damaged, turn off the boiler and fuse switches and never use the boiler.
- Only Authorized Service personnel should replace the power cables of the boiler and accessories.
- Do not expose the hanged boiler to direct steam that mightcome from cooking areas.
- Prevent the use of boiler by children and inexperienced people.

3.2. SELECTION OF SWITCHING ON / OFF / STAND-BY AND SUMMER / WINTER MODES

Use the V automat switch to cut the electrical connection to the boiler. If there is a double line on the display when electric is supplied to the device, the device is switched off. Refer to the ON-OFF Mode procedure in this section to operate the device in Winter or Summer mode.

3.2.1. Positions of Switching On / Off / Summer and Winter

Use the V automat (fuse) switch to switch on / off the electrical connection of the boiler.

Pos No	Operation	Description
0		In case there is an ERROR occur on the boiler. Press RESET button ones to remove the error code on the screen.
1		ERROR code shown the screen with " PUSH the RESET BUTTON" symbol.

Control Panel of Viwa 90-150 Boilers

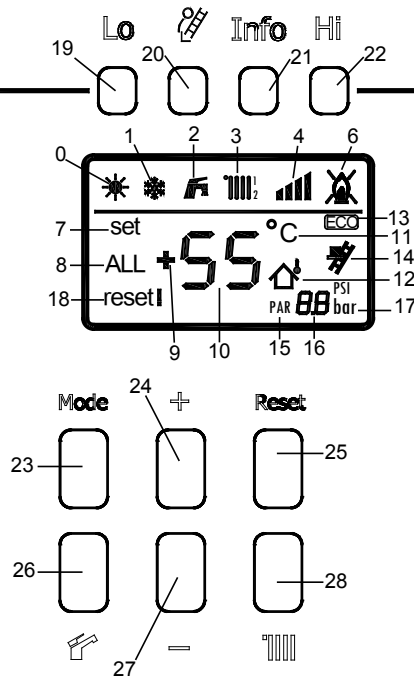







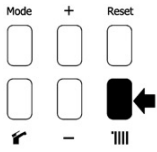
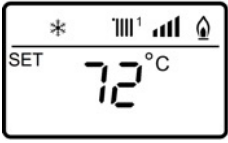
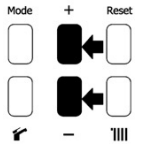
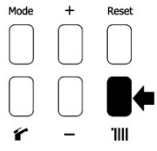
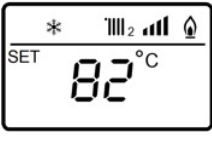
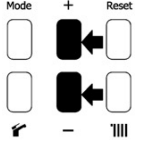
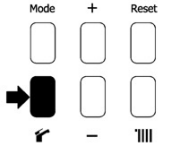
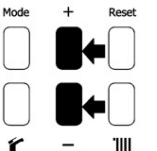

Figure 3.1 Control panel of Viwa 90-150 boilers

SCREEN SYMBOLS			
Tanım: Viwa 90 - 115 - 125 - 150			
POS NO	Sembol	Açıklama	Kullanım
0		Op. Mode Summer	Symbol lit (if boiler is in Summer mode) during Stand-by, Antifreeze, DHW.
1		Op. Mode Winter	Symbol lit (if boiler is in Winter mode) during Stand-by, Anti-freeze, Heating, DHW.
2		DHW operation	Symbol lit during DHW operation and during DHW set temperature setting procedure.
3		Heating Operation	Symbol lit during heating operation (symbols 1 and 2 lit individually or together based on whether the request arises from zone 1, zone 2 or both, radiator symbol always present, either fixed or flashing in the presence of heat request from zone 3) and during the setting procedure for the heating set temperature value (symbols 1 and 2 lit individually based on whether you are setting the set Temperature for zone 1 or zone 2, radiator symbol without other symbols indicates set temperature for zone 3).
4		Power Bar	Indication of the instant power level of the boiler. Lit during any type of burner operation: - First segment only if power is between 0% and 25% - First two segments if power is between 25% and 50% - First three segments if power is between 50% and 75% - All segments if power is between 75% and 100%
5		Flame present	Symbol lit during burner operation if the flame control device is detecting a flame (even in the presence of remote control). Symbol flashing when flame detection circuit is in error mode (parasite flame) in addition to fixed lighting of associated alarm code.
6		lockout caused by No Flame	Flashing 1 symbol if the boiler is in Lockout error mode due to no flame in addition to (fixed) lighting of associated alarm code.
7		Setting Values	Symbol lit when it is possible to set Heating Set Temperature values; (Z1, Z2, Z3) and DHW Set Temperature values. Symbol lit when it is possible to set installer parameter values and OEM values.
8		Alarm	Symbol lit when the boiler is in error mode together with associated alarm code and any other specific symbols.
9		Sign	Signs + and - to be used each time you need to view or set a value by increasing or decreasing (e.g. values associated with an offset) or a negative value.

10		Main Digits	<p>Digits used to display values for:</p> <ul style="list-style-type: none"> - Delivery probe during heating stage, stand-by and all inertia discharges (post-circulation or post-ventilation, also at the end of a DHW stage). - DHW probe during DHW stage. - Flashing of heating/DHW set value during associated setting procedure. - Flashing of value for parameter during associated setting procedure or reading. - Several values in sequence pressing button P1 (see dedicated chapter) - Several values in sequence during the panel testing procedure (see dedicated chapter) - Alarm codes preceded by "ALL" symbol - Dedicated compositions in the special cases described below.
11		Degrees Celsius	Symbol lit when the information shown in the main digits is a temperature as celcius.
12		External Temperature	Symbol lit when the information shown in the main digits is the external temperature and during external probe anti-freeze.
13		Presence of alternative sources	Symbol lit when the alternative sources function is active
14		Chimney sweeping function active	Symbol flashing when the chimney sweeping function is active.
15		Parameter	Symbol lit in front of number identifying parameter (secondary digits) when it is possible to display the parameter settings.
16		Secondary Digits	<p>Digits used to display values for:</p> <ul style="list-style-type: none"> - Pressure value in OFF mode - Pressure value in Stand-by, Heating, DHW, Anti-freeze, Alarm modes (except water pressure alarms) - Flashing of pressure value during high and low system water pressure errors. - Identification number of parameter during the display or adjustment of parameters. - Identification number of information displayed, accessing installer information using button P1. - Identification number of step in the panel testing procedure.
17		Bar	Symbol lit when the information shown in the secondary digits is a pressure value for the Europe version.
18		Reset Available	Symbol flashing when reset of an error or automatic lock-out conditions are available.

SET CH & DHW Temperatures

Pos No	Operation	Description
0		To set Central heating Zone 1 temperature value, Push RADİTATOR button at ones.
1		On the screen RADIATOR ZONE 1 shown and value start blinking.
2		From this moment toggle; (+) to increase set temperature OR (-) to decrease set temperature after some seconds the vallue will be saved automatically.
3		To set Central heating Zone 2 temperature value, Push RADİTATOR button ONE MORE TIME.
4		On the screen RADIATOR ZONE 2 shown and value start blinking.
5		From this moment toggle; (+) to increase set temperature OR (-) to decrease set temperature after some seconds the vallue will be saved automatically.
6		To set Domestic Heating Water temperature (DHW) value, Push TAP button at ones.
7		From this moment toggle; (+) to increase set temperature OR (-) to decrease set temperature after some seconds the vallue will be saved automatically.

Author	İsmail B. Taşdemir / R&D Mng.	Appr.:	As this is the property of Warmhaus Isıtma ve Sogutma Sistemleri San. Tic. A.Ş. It must not be passed on to any person not authorized by Warmhaus Isıtma ve Sogutma Sistemleri San. Tic. A.Ş or be copied or otherwise utilized by anybody without expressed written permission.
Release date	17.05.2018		
Rev. No:	0		
Drw. No:	WH.17.722		

Operating in Winter Position

When the boiler is in this position, it operates both to heat the environment and to obtain hot domestic water (if a boiler is connected).

Operating in Summer Position









If a boiler is connected to the boiler, it only operates for heating hot domestic water in this position.





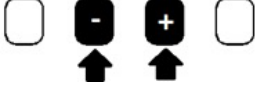



3.2.2. Resetting the Boiler (Restart)

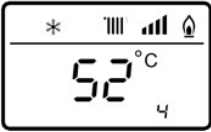

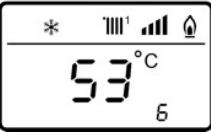
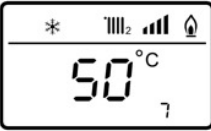





If the device is faulty/locked, you can reset the device by pressing the **RESET** button and repeat the re-start process again. For this purpose, perform the following:

RESET: In case of a fault of boiler, it is used to restart the boiler is and to recover the fault.

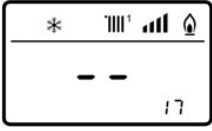
MODE: Used for setting the Winter/Summer/OFF mode.

INFO Menu		
Pos No	Operation	Description
0		Attention: This procedure must be applied by authorised persons and valid for only condensing boiler.
1	Lo  Info Hi 	Push INFO button at ones.
2		The screen bottom right will appear INFO as sample; on the middle Value = -5 (if external sensor connected, value could be different according to current out side temperature) INFO:1
3	Lo  Info Hi 	From this moment toggle; INFO (+) to increase OR CHIMNEY SWEEP (-) to decrease any INFO aimed to be checked.
4		INFO 1: Display of external temperature sensor. Value is available ONLY / WHEN sensor connected. IF the sensor not available OR not connected the value shown as " - - "
5		INFO 2: Display of heating flow (CH) temperature sensor.
6		INFO 3: Display of domestic hot water (DHW) temperature sensor. Value is available ONLY / WHEN sensor connected. IF the sensor not available OR not connected the value shown as " - - "

7		INFO 4: Display of Plant Probe temperature sensor OR AUX sensor temperature (selectable by Par=52). Value is available ONLY / WHEN sensor connected. IF the sensor not available OR not connected the value shown as " - - "
8		INFO 5: Display of fume temperature sensor. Value is available ONLY / WHEN sensor connected. IF the sensor not available OR not connected the value shown as " - - "
9		INFO 6: Display of heating flow (CH) SET temperature ZONE 1. Value is available ONLY / WHEN sensor connected. IF the sensor not available OR not connected the value shown as " - - "
10		INFO 7: Display of heating flow (CH) SET temperature ZONE 2.
11		INFO 8: Display of ionisation current (µA).
12		INFO 9: Display of fan speed in rpm x100. (ie. 33 x 100 = 3300 rpm)
13		INFO 10: Display of number of hours of the burner in hour x 100 (ie. 6.8 x 100 = 6800 hours)
14		INFO 11: Display of number of times the burner has ignited x 1000 (ie. 23 x 1000 = 23.000 times)
15		INFO 12: Display of number of total number of errors. (ie. 18 = 18 times)
16		INFO 13: Display of number of INSTALLER parameters (Par 1-49) accessed. Counter-installer. (ie. 15 = Parameter menu Par 1 - 49 has been 15 times activated)

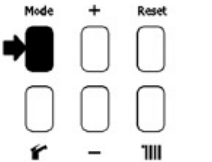
17		INFO 14: Display of number of OEM parameters (Par 51-99) accessed. Counter-OEM (ie. 11 = Parameter menu Par 51 - 99 has been 11 times activated)
18		INFO 15: Access counter parameters CASCADE OEM (ie. 4 = 4 access)
19		INFO 17: Not used.
20		INFO 18: Display of heating return (CH) temperature sensor.
21		INFO 19: Display of CASCADE flow temperature sensor. Value is available ONLY / WHEN sensor connected. IF the sensor not available OR not connected the value shown as " - - "
22		INFO 40: Display of % Value pump control PWM. Value is available ONLY / WHEN PWM pump connected.
23		INFO 60: Code of last recorded error. (ie. E06)
24		INFO 61: Code of penultimate recorded error. (ie. E02)
26		To exit the INFO menu push the MODE button at ones.

Author	Ismail B.Taşdemir / R&D Mng.	Appr.:	As this is the property of Warmhaus Isıtma ve Sogutma Sistemleri San. Tic. A.Ş. It must not be passed on to any person not authorized by Warmhaus Isıtma ve Sogutma Sistemleri San. Tic. A.Ş or be copied or otherwise utilized by anybody without expressed written permission.
Release date	17.05.2018		
Rev. No:	0		
Drw. No:	WH.17.720		

3.2.3. Operating in Winter Position

When the boiler is in this position, it operates both to heat the environment and to obtain hot domestic water (if a boiler is connected). The temperature setting of the heater is set by pressing the Heating button and then the (+) and (-) buttons on the display as shown in the procedure "Heater and Hot Domestic Water Temperature Set" (page 28).

3.2.4. Operating in Summer Position (if a boiler is connected)

When the boiler is in this position, it operates only for heating hot domestic water. Press the TAP button once, as indicated in step 6 in the procedure "Heater and Hot Domestic Water Temperature Set" (page 28) and then set the hot domestic water temperature with the (+) and (-) buttons.

3.2.5. Use with Room Thermostat (Optional)

The boiler is pre-prepared for the remote control connection with the ambient thermostats being sold as optional set. All Warmhaus thermostats can be connected with bifilar cable. Carefully read the instructions for use and installation contained in the accessory set. Thanks to the program-time room thermostat control units, you can control your boiler from the place where it is mounted (for example from the hall), operate according to the room temperature and at the same time, use differently according to every day of the week.

Important: If the Remote Control is used in any thermostat as On/Off of, there is a requirement to have two separate lines in accordance with the applicable legal regulations for electrical installations. It is not permissible to use any pipes or hoses of the boiler as electricity or telephone grounding lines. This must be ensured before the electrical connections of the boiler are made.

General Use

- Consult our authorized dealers/service for room thermostats compatible with Warmhaus boilers.
- Do not remove the parts of the device while it is running.
- Do not place it under direct sunlight or near heat sources.
- The manufacturer cannot be held responsible for the following situations:
 - a) Incorrect mounting
 - b) Unauthorized intervention to the device
 - c) Failure to comply with the instructions in this booklet and in the room thermostat booklet.

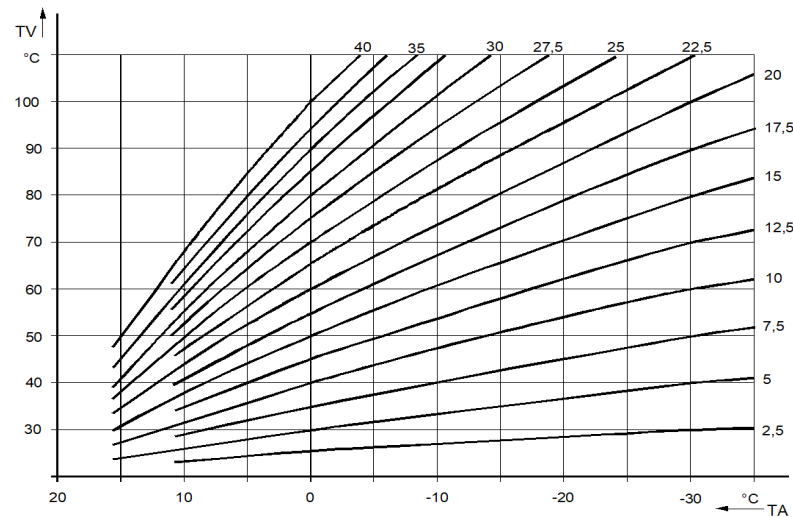

Şekil 3.3 Dış hava sıcaklık sensörü çalışma eğrileri

Maintenance and Lifetime: The Warmhaus room thermostat should not contact with water or excessive moisture. Your room thermostat does not require any maintenance unless there is damage from outside. The lifetime is 5 years.

3.2.6. Use of Outside Temperature Sensor (Optional)

Outside Temperature Sensor (optional): Thanks to this optional accessory you can connect to your device by our Authorized Service (see: Mounting Part, Accessory Connection Diagram), you can instantly react to outside temperature changes with a smart and comfortable operation and set heater temperature automatically.



In this way, it releases you of constant heater temperature setting and enables an efficient and economical operation according to your needs by reducing the temperature of heater water when the outside temperature starts to rise and rising the temperature of heater water proportionally when the outside temperature decreases. This sensor is activated when connected independently of the presence or typology of the thermostat used, the relationship between the stream temperature of the installation and the outside temperature is determined according to the curve presented in the graphic below with respect to the position of the button on the boiler panel.

Once the Outside Temperature Sensor is connected, the P04 parameter is set to the average outside temperature of the city you live in. This setting will be made by our Authorized Service during installation.

3.2.7. Customization of Boiler Features



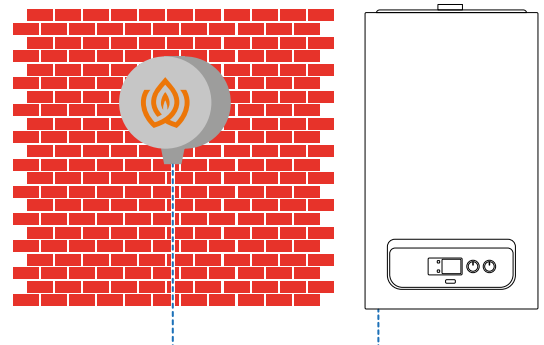



As your boiler has an advanced electronic card, some parameters related to its operating conditions and preferences can be changed by our Authorized Service.







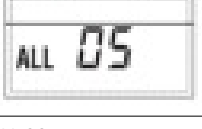

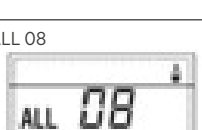
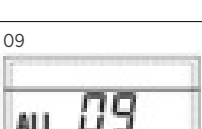

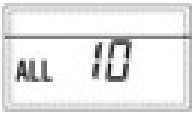
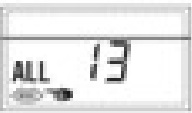
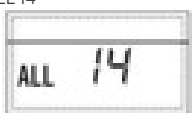
Şekil 3.2 Exterior temperature sensor

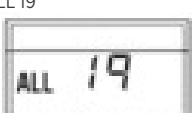
3.3. FAULT FINDING & SOLUTIONS

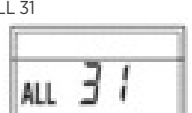
3.3.1. Arıza Kodları Tablosu

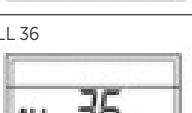
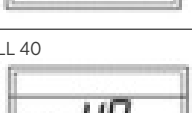
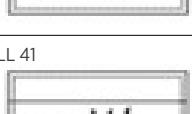
Fault Finding & Solutions				
Object: Viwa 90 - 115 - 125 - 150				
 <p>This document has been composed to find possible faults and solve Attention: This procedure must be applied by authorised persons.</p>				
Error Code	Description of the Error	Malfunction	Probable Cause	Solution(s)
ALL 01	NA	NA	NA	
ALL 02 	Low water pressure in the system/system parameter wrongly setted	Boiler does not work, ALL 02 error code flashing on the screen	> Water pressure in the boiler not enough > TsP Parameter wrongly settled (PAR4 must be 2)	1-) Fill the boiler 1,5-2 bar 2-) Check if the system pressure 1,5 - 2 bar from the LCD display 3-) If problem persist Call for authorised service 4-) Reset & Restart boiler
ALL 03 	High water pressure in the system	Boiler does not work, ALL 03 error code flashing on the screen	> High Water pressure in the boiler higher than > 5,5 bar	1-) Drain the boiler water until 1,5-2 bar 2-) Check if the system pressure 1,5 - 2 bar from LCD display 3-) If problem persist Call for authorised service 4-) Check expansion vessel pre set air AND/OR tank membrane 5-) Reset & Restart boiler
ALL 04 	Domestic heating water temperature sensor faulty	Boiler does not work on DHW mode but still work on Central heating mode, ALL 04 error code flashing on the screen	> Domestic heating water temperature sensor faulty > DHW sensor not connected > PAR2 wrong setting	1-) Call for authorised service at first
ALL 05 	Central heating FLOW temperature sensor faulty	Boiler does not work, ALL 05 error code flashing on the screen	> Central heating FLOW temperature sensor faulty > flow sensor is open or short circuit	1-) Call for authorised service at first 2-) Reset & Restart boiler
ALL 06 	No ignition Flame is not detected	Boiler does not work, ALL 06 error code flashing on the screen	> Gas supply failure	1-) RESET boiler at first check if problem removed 2-) Check other gas devices if they are working 3-) Check main gas supply valve is open or not 4-) Check boiler gas supply valve below the boiler is open or not 5-) RESET boiler at first check if problem removed 6-) Call for authorised service at first
ALL 07 	Safety/Limit thermostat intervention	Boiler does not work, ALL 07 error code flashing on the screen Water overtemperature (T>95°C)	> Lack of water on the system > Pump blockage > Pump failiure > Pump harness > Installation blockage	1-) RESET boiler at first check if problem removed 2-) Check boiler central heating valves are open if they are closed open of all 3-) Check all radiator valves are open if they are closed open of all minimum 3 meters of radiator must be open 4-) RESET boiler and check if problem removed 5-) Call for authorised service at first
ALL 08 	Flame circuit failure / Flame detection error	If the flame control section recognises the presence of a flames in pahases when they should not be present, it means that there is a breakdown in flame detection circuit	> Aging or rust on the electrode > Electrode position > Cabeling disconnections > Water blokage on syphon > Electronic board	1-) Call for authorised service at first
E 09 	No water circulation in the system	Boiler does not work, ALL 09 error code flashing on the screen Flow temperature sensor has detected a temperature rise in excess of 5°C/sec	> Lack of water on the system > Pump blockage > Pump failiure > Pump harness > Installation blockage	1-) RESET boiler at first check if problem removed 2-) Check boiler central heating valves are open if they are closed open of all 3-) Check all radiator valves are open if they are closed open of all minimum 3 meters of radiator must be open 4-) RESET boiler and check if problem removed 5-) Call for authorised service at first

<p>ALL 10</p> 	Plant Probe OR AUX Probe temperature sensor faulty	Boiler does not work, ALL 10 error code flashing on the screen	<ul style="list-style-type: none"> > Plant probe OR AUX Probe temperature sensor faulty > Plant Probe OR AUX sensor is open or short circuit 	<ul style="list-style-type: none"> 1-) Reset & Restart boiler 2-) Call for authorised service at first
<p>ALL 13</p> 	Exhaust temperature probe over-temperature alarm	Boiler does not work, ALL 13 error code flashing on the screen	<ul style="list-style-type: none"> > Over temperature flue gas outlet value > P80 value C° 	<ul style="list-style-type: none"> 1-) Reset & Restart boiler 2-) Call for authorised service at first
<p>ALL 14</p> 	Exhaust (FLUE) temperature probe fault	Boiler does not work, ALL 14 error code flashing on the screen	<ul style="list-style-type: none"> > Central heating FLUE temperature sensor faulty > Probe is open or short circuited 	<ul style="list-style-type: none"> 1-) Reset & Restart boiler 2-) Call for authorised service at first
<p>ALL 15</p> 	Fan failure (feedback/ supply)	Boiler does not work, ALL 15 error code flashing on the screen	<ul style="list-style-type: none"> > Fan harness 	<ul style="list-style-type: none"> 1-) Reset & Restart boiler 2-) Call for authorised service at first
<p>ALL 19</p> 	Fault failure external probe	This error is activated when the external probe is short-circuited The  symbol is shown flashing on the display	<ul style="list-style-type: none"> > external probe is short-circuited 	<ul style="list-style-type: none"> 1-) Reset & Restart boiler 2-) Call for authorised service at first
<p>ALL 30</p> 	Return probe temperature sensor faulty	Boiler does not work, ALL 30 error code flashing on the screen	<ul style="list-style-type: none"> > Return Probe temperature sensor faulty > Return sensor is open or short circuit 	<ul style="list-style-type: none"> 1-) Reset & Restart boiler 2-) Call for authorised service at first
<p>ALL 31</p> 	Cascade Delivery Sensor Alarm	Usable RESET number reached.	Too many consecutive lock-out failures (followed by reset) due to other possible causes	<ul style="list-style-type: none"> 1-) Reset & Restart boiler 2-) If fault still persists call for authorised service
<p>ALL 35</p> 	Communication Error Between UI 30 board and UI 30 Board (between two cascade module)	Boiler does not work, ALL 35 error code flashing on the screen	When PAR 15 is different from" - - " and there isn't communication between UI 30 board and UI 30 board the boiler stop and the display shows ALL 35.	<ul style="list-style-type: none"> 1-) Reset & Restart boiler 2-) If fault still persists call for authorised service
<p>ALL 36</p> 	Cascade Adress Error	Boiler does not work, ALL 36 error code flashing on the screen	When PAR 15 is adressed for two or more boilers as SAME ADRESSED then boilers stop and the display shows ALL 36.	<ul style="list-style-type: none"> 1-) Reset & Restart boiler 2-) If fault still persists call for authorised service
<p>ALL 40</p> 	HEX heatexchanger protection temperature probe fault	Boiler does not work, ALL 40 error code flashing on the screen	<ul style="list-style-type: none"> > HEX temperature sensor faulty > Probe is open or short circuited 	<ul style="list-style-type: none"> 1-) Reset & Restart boiler 2-) If fault still persists call for authorised service
<p>ALL 41</p> 	HEX heat exchanger temperature probe over-temperature alarm	Boiler does not work, ALL 41 error code flashing on the screen Temp > Par 88 value	<ul style="list-style-type: none"> > Lack of water on the system > Pump blockage > Pump failiure > Pump harness > Installation blockage 	<ul style="list-style-type: none"> 1-) RESET boiler at first check if problem removed 2-) Check boiler central heating valves are open if they are closed open of all 3-) Check all radiator valves are open if they are closed open of make sure enough cooling into the system 4-) RESET boiler and check if fault still persists call for authorised service 5-) Call for authorised service at first

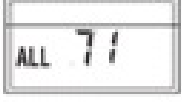
<p>ALL 70</p> 	<p>Cascade Error Mater boiler</p>	<p>Boiler does not work, ALL 70 error code flashing on the screen</p>	<p>Fault ALL 70 displayed only on the master boiler when an error is detected in the cascade system which prevents its operation.</p>	<p>1-) Call for authorised service at first 2-) Check slave boilers at first. 3-) Reset & Restart boiler</p>
<p>ALL 71</p> 	<p>Cascade Error</p>	<p>Boiler does not work, ALL 71 error code flashing on the screen</p>	<p>Fault ALL 71 displayed only on the master boiler in case of SMC probe fault (data not received or probe faulty)</p>	<p>1-) Removing power supply reset will be allowed 2-) Check the root cause of Error code to solve 3-) Check Cascade Sensor at first. 4-) If fault still persists call for authorised service</p>

3.4. SUGGESTIONS FOR USING BOILER ECONOMICALLY

Your boiler is set to ECO mode for economic use, we recommend not to change it.

Choosing the Right Capacity

The heat loss calculation for the space where the boiler will be used must be made correctly and the boiler capacity must be suitable for this. Devices that do not have sufficient capacity will respond to warming requests later, and over-capacity devices may cause inconvenience and more fuel consumption as they will be activated and deactivated more frequently. For this reason, the boiler capacities should be chosen suitable for the place where it will be used.

Insulation

The insulation of your building is the most important factor that prevents heat loss and reduces gas consumption. However, the heat loss is minimized because your boiler has the highest insulation thickness of its class.

Radiators

Balance the pressure distribution of your domestic heating installation by turning radiator valves down. Placing furniture in front of the radiators prevents air circulation, resulting in inconvenience and more fuel consumption. Turning down the radiator valves of the unoccupied rooms for a long time or if the thermostatic radiator valve is used, bringing it to the lowest position and closing the doors of these rooms provide savings.

Domestic Hot Water

If you are using the boiler with a hot domestic water boiler, it is recommended to set the Hot Domestic Water temperature as (38-42°C). Setting the water heater to a low value provides a large amount of energy saving.

Thermostatic Radiator Valves

By using Thermostatic Radiator Valves, you can achieve both savings and comfort by balancing the heat distribution in the home ambient.

Room Thermostats

With room thermostats, you will have the opportunity to adjust the desired ambient temperature according to comfort and economy times, so your boiler will operate more economically. This way you can set the temperature of your room as you like, and you get about 6% energy savings with every decreasing degree of temperature.

Ventilation

Do not leave the windows in a little open position to ventilate the room/rooms. In this case, there will be constant heat loss from the room but there will be no significant improvement in room air. It is better to open windows completely for a short period of time.

Turn the thermostatic radiator valves down to the lowest position while venting the rooms.

3.5. POINTS TO CONSIDER BY USERS FOR WARRANTY CONDITIONS

This warranty granted by WARMHAUS does not cover damages arising from abnormal use of product and the following conditions are out of warranty:

1. Damage and failures in devices of which first operations are not started by Warmhaus Authorized Services,
2. Damage and failures due to use against issues in the Product's User Manual and out of purpose,
3. Damage and failures due to incorrect type selection,
4. Damage and failures due to maintenance and repairs by persons other than our Authorized Service personnel,
5. Damage and failures due to transportation, unloading, loading, storage, external physical (crashing, scratching, breaking) and chemical agents after delivery of the product,
6. Damage and failures due to fire and lightning,
7. Damage and failures due to incorrect use of fuel and fuel properties,
8. Damage and failures due to brownout or over-voltage; use of ungrounded socket; incorrect electric installation
9. The annual maintenance and cleaning to be done by our Authorized Services,
10. Damage and failures due to the failure to perform the described periodic maintenance on time,
11. Damage and failures that may occur in the device or in the field of use due to other products and accessories used in a system with the guaranteed device,
12. Damage and failures due to freezing/icing or use in open spaces (open balcony etc.)
13. Falsification of the Registration Label and Warranty Document,
14. Damage and failures due to the use with water values other than ones described in the device's user manual,

The abovementioned damages are removed against a fee. The warranty is valid for the period specified on the other side of this document and only for defects that occur in the product. Dear our Customer, we believe in importance of providing you with good products as well as good service. For this reason, in your all service needs related to our products, you can get information and contact our company by

Suggestions and Information to Observe:

1. Keep the technical service document given to you by the Authorized Service after the first operation of your boiler, and a copy of the device's invoice and the Warranty approved by the Authorized Dealer.
2. Use your product according to mounting and operating instructions.

TEKNİK VERİLER		Viwa 90	Viwa 155	Viwa 125	Viwa 150
Gas Circuit					
	Birim				
Gas type		G20	G20	G20	G20
Gas supply pressure	mbar	20	20	20	20
Gas Consumption at Maximum	m ³ /h	9,301	11,55	12,737	15,27
Gas Consumption at Minimum	m ³ /h	1,538	1,787	2,005	2,419
*(Natural Gas G20) Heat Load (Hu=10,56 kWh/m ³)					
Premix System		Pneumatic			
Modulation Range		1:6			
Heat Exchanger Material		Al-Mg-Si			
Efficiency		G20	G20	G20	G20
(80/60 °C) Efficiency at Maximum Heat Output	%	97,72	97,46	97,78	97,58
(50/30 °C) Efficiency at Maximum Heat Output	%	103,59	102,67	103,6	103,04
Efficiency at 30% load at 36/30 °C	%	107,48	107,17	108,01	107,49
Radiator Circuit		G20	G20	G20	G20
Maximum heat input Qn	kW	90	115	125	150
Minimum heat input Qn	kW	14,5	17,5	20	24
Maximum Heat Output Pn (80/60 oC)	kW	87,9	112	122,2	146,3
Minimum Heat Output Pn (80/60 oC)	kW	13,23	15,38	17,82	21,62
Maximum Heat Output Pn (50/30 oC)	kW	93,2	118	129	154,5
Minimum Heat Output Pn (50/30 oC)	kW	16,08	19,04	20,81	25,05
Temperature selection range (min+max) high temperature	°C	25÷80			
Temperature selection range (min+max) low temperature	°C	25÷47			
Operating Pressure (Maximum)	bar	6			
Operating Pressure (Minimum)	bar	0,8			
Domestic Hot Water Circuit					
Temperature adjustment range	°C	20 - 65			
Electricity Circuit					
Electricity Supply	V AC-50 Hz	230 V +%10; -%15			
Electricity Consumption (Max./Min.)	Watt	29 / 120	30 / 128	29 / 169	30 / 265
Protection Index	IP	IPX5D			
Exhaust Gas Circuit		G20	G20	G20	G20
(80/60 °C) Exhaust gas temperature (Min. / Max.)	°C	53,5 / 61,7	52,5 / 67,8	56,4 / 58,7	56,9 / 67,6
(50/30 °C) Exhaust gas temperature (Min. / Max.)	°C	30,4 / 46,3	31,2 / 50,2	30,1 / 46,6	30,2 / 48,0
NOx	Class	6			
Weighted value of Nox (GCV)	mg/kWh	18	28	25	29
Flue mass flow rate (60/80°C - Qn) Nominal/Minimum	g/s	38,89 / 6,43	48,29 / 7,47	53,25 / 8,38	63,84 / 8,38
General					
Dimensions (H x W X D)	mm	725 x 612 x 490			
Sound Level	dB (A)	62,1	62,1	63,4	63,4
Net Weight	kg	70	70	82	82
Packed Device Weight	kg	87	87	99	99
Type		B 23, C 13, C 33, C 53, C 63, C 83			
Category		I2H/I2E/I2E(S)/ (G20=20mbar)			

Product Fiche & ErP Data			
Designation : Product FICHE & ErP Data Viwa 50 & 150			
Object	Manufacturer	Type-model / Technical data	Mark (s) of conformity
Product Fiche & ErP Data	Warmhaus	Viwa 50 & 150 boilers	granted

ErP & Product Fiche for Warmhaus boilers has been tested and reported on SZU Test / BRNO given below

PRODUCT FICHE (according to EU regulation No 811/2013 and 814/2013)

		Viwa 50	Viwa 65	Viwa 90	Viwa 115	Viwa 125	Viwa 150
Space heating - Temperature application		High / Medium / Low					
Water heating - Declared load profile		—	—	—	—	—	—
Seasonal space heating energy efficiency class		A	A	—	—	—	—
Water heating energy efficiency class		—	—	—	—	—	—
Rated heat output (Prated or Psup)		48,7	63,2	87,9	112	122,2	146,3
Space heating - annual energy consumption	Q _{HE}	GJ	—	—	—	—	—
		kWh (*)	—	—	—	—	—
Water heating - Annual energy consumption		GJ (**)	—	—	—	—	—
		%	92	93	—	—	—
Seasonal space heating energy efficiency		%	—	—	—	—	—
Water heating energy efficiency		%	—	—	—	—	—
Sound power level LWA indoors		dB	61	58	62,1	62,1	63,4
Option to only operate during low demand periods			—	—	—	—	—
Specific precautions for assembly, installation and maintenance			Before any assembly, installation or maintenance the user and installation manual has to be read attentively and to be followed				

All the data that is included in the product information was determined by applying the specifications of the relevant European directives. Differences to product information listed elsewhere may result in different test conditions. Only the data that is contained in this product information is applicable and valid.

(*) Electricity

(**) Fuel

ErP DATA (according to EU regulation No 813/2013 and 814/2013)

			Viwa 50	Viwa 65	Viwa 90	Viwa 115	Viwa 125	Viwa 150
Water heating - Declared load profile			—	—	—	—	—	—
Rated Heat Output	Prated	kW	48,7	63,2	87,9	112	122,2	146,3
Useful heat output at rated heat output and high temperature regime (2)	P ₄	kW	45,73	57,78	80,93	101,32	113,32	136,01
Useful heat output at 30% of rated heat output and low temperature regime (1)	P ₁	kW	8,12	11,54	15,26	20,17	22,75	25,63
Seasonal Space Heating Energy Efficiency	η _s	%	92	93	-	-	-	-
Useful efficiency at rated heat output and high temperature regime(2)	η ₄	%	88	87,8	88,07	87,83	88,15	87,98
Useful efficiency at 30% of rated heat output and low temperature regime(1)	η ₁	%	97,11	97,39	96,87	96,58	97,38	96,91
Auxiliary Electricity Consumption								
Full load	elmax	kW	0,09	0,10	0,120	0,128	0,169	0,265
Part load	elmin	kW	0,01	0,03	0,029	0,030	0,029	0,030
Standby mode	P _{SB}	kW	0,004	0,004	0,004	0,004	0,004	0,004
Other Items								
Standby heat loss	P _{Stby}	kW	0,073	0,073	0,121	0,121	0,127	0,127
Ignition burner power consumption	P _{ign}	kW	0,000	0,000	0,000	0,000	0,000	0,000
Space heating - annual energy consumption	Q _{HE}	GJ	—	—	-	-	-	-
Sound power level, indoors	L _{WA}	dB	61	58	62,1	62,1	63,4	63,4
Emissions of nitrogen oxides	NO _x	mg/kWh	40	40	18	28	25	29
Domestic Hot Water Parameters								
Declared Load Profile								
Daily electricity consumption	Q _{elec}	kWh	—	—	-	-	-	-
Annual electricity consumption *	AEC	kWh	—	—	-	-	-	-
Water Heating Energy Efficiency	h _{wh}	%	—	—	-	-	-	-
Daily fuel consumption	Q _{fuel}	kWh	—	—	-	-	-	-
Annual fuel consumption	AFC	GJ	—	—	-	-	-	-
Condensing boiler			Yes	Yes	Yes	Yes	Yes	Yes
Low temperature boiler			Yes	Yes	Yes	Yes	Yes	Yes
Combination boiler			No	No	No	No	No	No
B1 Boiler			No	No	No	No	No	No
Room boiler with combined heat and power			No	No	No	No	No	No
Auxiliary boiler			No	No	No	No	No	No
Brand Name			Warmhaus					
Manufacturer address			Warmhaus Isıtma ve Sogutma Sistemleri San. Tic. A.Ş. Nilufer Organize Sanayi Bolgesi Selvi Cad. No:3 Nilufer/Bursa/TÜRKİYE					
Warnings 	All specific precautions for assembly, installation and maintenance are described in the operating and installation manual. Read and follow the operating and installation manual.							
	Read and follow the operating and installation manual regarding assembly, installation, maintenance, removal, recycling and/or disposal.							

* for average climatic conditions

(1) Low temperature means for condensing boilers 30 oC, for low temperature boilers 37 oC and for other heaters 50 oC return temperature (at heater inlet).

(2) High temperature regime means 60 oC return temperature at heater inlet and 80 oC feed temperature heater outlet.

Author	İsmail B. Taşdemir / R&D Mng.	Appr.:	As this is the property of Warmhaus Isıtma ve Sogutma Sistemleri San. Tic. A.Ş. It must not be passed on to any person not authorized by Warmhaus Isıtma ve Sogutma Sistemleri San. Tic. A.Ş or be copied or otherwise utilized by anybody without expressed written permission.
Release date	22.05.2018		
Rev. No:	0		
Drw. No:	WH.17.747		

VIWA 150

CE
1015 18

EAC LOGO

I 2H (20 MBAR)	AT, BG, CH, CZ, DK, EE, ES, FI, GB, GR, HR, IE, IT
I 2H (20 MBAR)	LT, LV, NO, PT, RO, SE, SI, SK, TR
I 2H (25 MBAR)	HU
I 2E (20 MBAR)	DE, LU, PL, RO
I 2E(S) (20 MBAR)	BE

The maximum water pressure PMS:	CH= 6.0 bar
The electrical supply:	-230 VAC (+10%/-15%) and 50 Hz
The rated electrical power input:	265 W
The type of boiler:	Premix Condensing Boiler
Heat input Qn [kW] (Min/Max)	24 - 150 kW
Maximum water service pressure CH (PMS)	6.0 bar
Protection class:	IP X5D
GC NO	

EANKODU

Production Date

UKRSEPRO LOGO

Weight: 99,0 kg
Size: 76x87x68 cm

Gas Categories	G20
Maximum heat input Qn [kW]	150
Minimum heat input Qn [kW]	24
Δt (50/30°)	
Maximum heat output Pn [kW]	146,3
Minimum heat output Pn [kW]	21,62

B₂₃ C₁₃ C₃₃ C₅₃ C₆₃ C₈₃

I2H / I2E / I2E(S) - G20 - 20 MBAR

METANO
NATURAL GAS

READ THE
INSTRUCTION OF
THE BOILER BEFORE
INSTALLATION !!!

READ THE
INSTRUCTION OF
THE BOILER BEFORE
START UP THE
BOILER !!!

SERİ NO

MADE IN TURKEY

Warmhaus İstima ve Soğutma Sistemleri San. A.Ş.
Nilüfer Organize Sanayi Bölgesi, Selvi Caddesi, No: 3
Nilüfer 16140, Bursa, Türkiye
T: +90 224 295 94 00 F: +90 224 411 23 77 info@warmhaus.com.tr

 **warmhaus**

VIWA 125

CE
1015 18

EAC LOGO

I 2H (20 MBAR)	AT, BG, CH, CZ, DK, EE, ES, FI, GB, GR, HR, IE, IT
I 2H (20 MBAR)	LT, LV, NO, PT, RO, SE, SI, SK, TR
I 2H (25 MBAR)	HU
I 2E (20 MBAR)	DE, LU, PL, RO
I 2E(S) (20 MBAR)	BE

The maximum water pressure PMS:	CH= 6.0 bar
The electrical supply:	-230 VAC (+10%/-15%) and 50 Hz
The rated electrical power input:	169 W
The type of boiler:	Premix Condensing Boiler
Heat input Q _n [kW] (Min/Max)	20 - 125 kW
Maximum water service pressure CH (PMS)	6.0 bar
Protection class:	IP X5D
GC NO	

EAN KODU

Production Date

UKRSEPRO
LOGO

Weight: 99.0 kg
Size: 76x87x68 cm

Gas Categories	G20
Maximum heat input Q _n [kW]	125
Minimum heat input Q _n [kW]	20
Δt (50/50°)	
Maximum heat output P _n [kW]	122,2
Minimum heat output P _n [kW]	17,82

B₂₃ C₁₃ C₃₃ C₅₃ C₆₃ C₈₃

I2H / I2E / I2E(S) - G20 - 20 MBAR

METANO
NATURAL GAS

READ THE
INSTRUCTION OF
THE BOILER BEFORE
INSTALLATION !!!

READ THE
INSTRUCTION OF
THE BOILER BEFORE
START UP THE
BOILER !!!

SERİ NO

MADE IN TURKEY

 **warmhaus**

Warmhaus Isıtma ve Soğutma Sistemleri San. A.Ş.
Niüfer Organize Sanayi Bölgesi, Selvi Caddesi, No: 3
Niüfer 16140, Bursa, Türkiye
T: +90 224 295 94 00 F: +90 224 411 23 77 info@warmhaus.com.tr

VIWA 115



1015 18

EAC LOGO

I 2H (20 MBAR)	AT, BG, CH, CZ, DK, EE, ES, FI, GB, GR, HR, IE, IT
I 2H (20 MBAR)	LT, LV, NO, PT, RO, SE, SI, SK, TR
I 2H (25 MBAR)	HU
I 2E (20 MBAR)	DE, LU, PL, RO
I 2E(S) (20 MBAR)	BE

The maximum water pressure PMS:	CH= 6.0 bar
The electrical supply:	~230 VAC (+10%/-15%) and 50 Hz
The rated electrical power input:	128 W
The type of boiler:	Premix Condensing Boiler
Heat input Q _n [kW] (Min/Max)	17.5 - 115 kW
Maximum water service pressure CH (PMS)	6.0 bar
Protection class:	IP X5D
GC NO	

EANKODU

Production Date

READ THE
INSTRUCTION OF
THE BOILER BEFORE
INSTALLATION !!!

READ THE
INSTRUCTION OF
THE BOILER BEFORE
START UP THE
BOILER !!!

SERİ NO

UKRSEPRO
LOGO

Weight: 87.0 kg
Size: 76x87x68 cm

Gas Categories	G20
Maximum heat input Q _n [kW]	115
Minimum heat input Q _n [kW]	17,5
Δt (50/30°)	
Maximum heat output P _n [kW]	112
Minimum heat output P _n [kW]	15,38

B₂₃ C₁₃ C₃₃ C₅₃ C₆₃ C₈₃

I2H / I2E / I2E(S) - G20 - 20 MBAR

METANO
NATURAL GAS



Warmhaus İstima ve Soğutma Sistemleri San. A.Ş.
Niüfer Organize Sanayi Bölgesi, Selvi Cadde, No: 3
Niüfer 16140, Bursa, Türkiye
T: +90 224 295 94 00 F: +90 224 411 23 77 info@warmhaus.com.tr

MADE IN TURKEY

VIWA 90

CE
1015 18

EAC LOGO

I2H (20 MBAR)	AT, BG, CH, CZ, DK, EE, ES, FI, GB, GR, HR, IE, IT
I2H (20 MBAR)	LT, LV, NO, PT, RO, SE, SI, SK, TR
I2H (25 MBAR)	HU
I2E (20 MBAR)	DE, LU, PL, RO
I2E(S) (20 MBAR)	BE

The maximum water pressure PMS:	CH= 6.0 bar
The electrical supply:	-230 VAC (+10%/-15%) and 50 Hz
The rated electrical power input:	120 W
The type of boiler:	Premix Condensing Boiler
Heat input Qn [kW] (Min/Max)	14,5 - 90 kW
Maximum water service pressure CH (PMS)	6.0 bar
Protection class:	IP X5D
GC NO	

EAN KODU

Production Date

UKRSEPRO
LOGO

Weight: 87.0 kg
Size: 76x87x68 cm

Gas Categories	G20
Maximum heat input Qn [kW]	90
Minimum heat input Qn [kW]	14,5
Δt (50/30°)	
Maximum heat output Pn [kW]	87,9
Minimum heat output Pn [kW]	13,23

B₂₃ C₁₃ C₃₃ C₅₃ C₆₃ C₈₃

I2H / I2E / I2E(S) - G20 - 20 MBAR

METANO
NATURAL GAS

SERİ NO

READ THE
INSTRUCTION OF
THE BOILER BEFORE
INSTALLATION !!!

READ THE
INSTRUCTION OF
THE BOILER BEFORE
START UP THE
BOILER !!!

 **warmhaus**

Warmhaus Isıtma ve Soğutma Sistemleri San. A.Ş.
Nispetiye Organize Sanayi Bölgesi, Selvi Caddesi, No: 3
Nispetiye 16140, Bursa, Türkiye
T: +90 224 295 94 00 F: +90 224 411 23 77 info@warmhaus.com.tr

MADE IN TURKEY

VIWA 90
VIWA 115
VIWA 125
VIWA 150

**INSTALLATION & USER MANUAL FOR
WALL MOUNTED CONDENSING BOILERS**

WARMHAUS 90-150 kW KAZAN KULLANMA KILAVUZU – İNG Kodu: 150.11.606.000044
Revizyon numarası: R02/10.2018